

# Spannsätze

## **RINGFEDER® RfN 7110**

### Montage, Demontage, erneute Montage

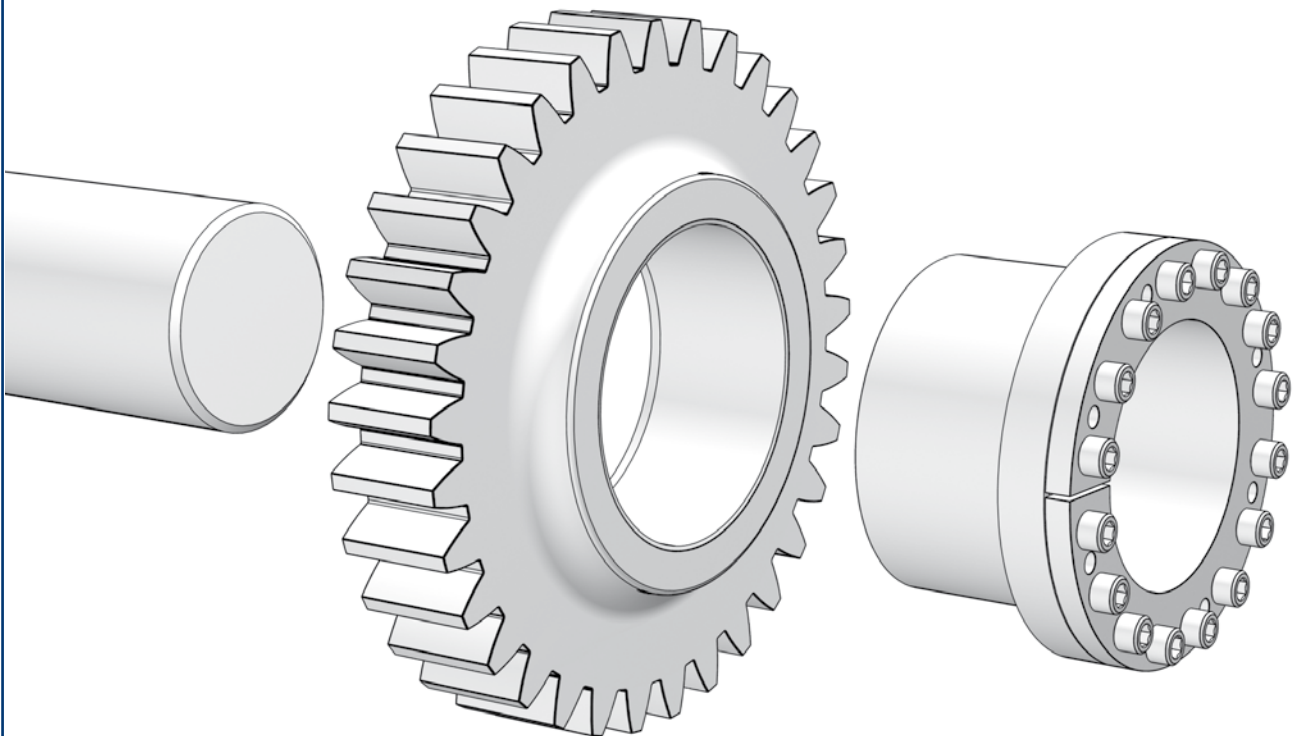

**RfN 7110**

einschließlich  
**RINGFEDER® RfN 7110 rostfrei**

## Sicherheitshinweise

Rotierende Maschinenteile können Bediener und Servicepersonal verletzen! Deshalb:

- Schalten Sie vor Montagearbeiten den Antrieb ab.
- Sichern Sie die Maschine gegen unbeabsichtigtes Einschalten.
- Montieren Sie vor Einschalten der Maschine alle Abdeckungen und Schutzeinrichtungen.
- Die Montage von RINGFEDER® Produkten darf nur durch fachkundiges Personal und für geeignete Anwendungsfälle erfolgen.

## Achtung

- Diese Anleitung bitte gründlich durchlesen.
- Bei Zuwiderhandlung gegen die Hinweise in dieser Anleitung besteht kein Haftungsanspruch.
- RINGFEDER POWER TRANSMISSION behält sich technische Änderungen zur Produktverbesserung vor.
- RINGFEDER® Spannsätze entsprechen dem anerkannten Stand der Technik.

**Bei Problemen oder Rückfragen stehen Ihnen unsere Mitarbeiterinnen und Mitarbeiter aus Technik und Service gerne zur Verfügung. Die entsprechenden Kontaktinformationen finden Sie auf der Rückseite dieser Anleitung.**

## Verwendete Schmiermittel

### Bezeichnung

Maschinenöl Shell Omala 220 oder vergleichbares

## Legende



Montage



Demontage



Erneute Montage



Reinigen



Nabe und Welle gegebenenfalls leicht einölen (keine MoS2-haltigen Öle verwenden).

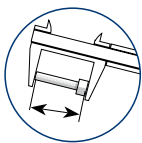

Schraube auf Verformung prüfen und gegebenenfalls austauschen.



Beschriebenen Vorgang über Kreuz in so vielen Durchgängen wie angegeben ausführen.



Beschriebenen Vorgang in so vielen Durchgängen wie angegeben ausführen.



Auf zulässige Rauhtiefe prüfen.



Achtung! Unbedingt beachten!



Gültige Daten über die erforderlichen Anzugsmomente können dem Product Paper & Tech Paper „Spannsätze“ sowie unserer Webseite entnommen werden. Bitte prüfen Sie, ob der Maschinen-/Anlagenbauer abweichende Anzugsmomente vorgegeben hat.

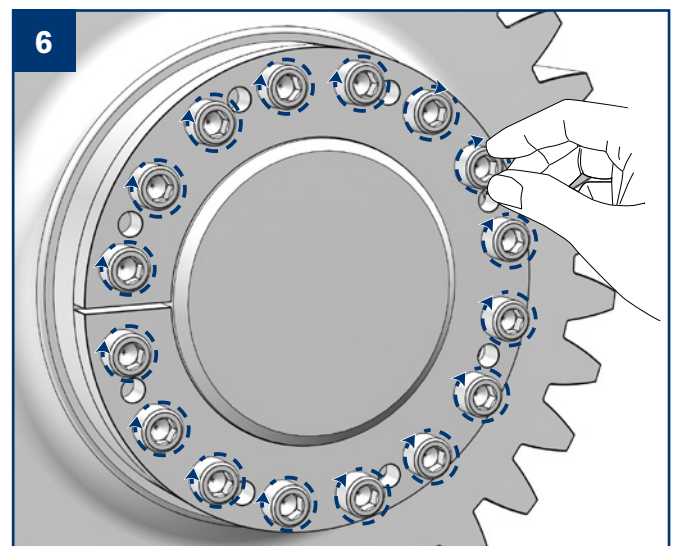
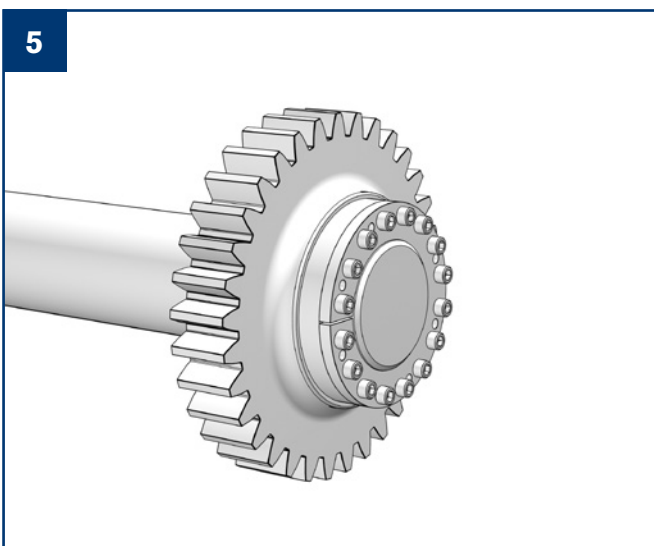
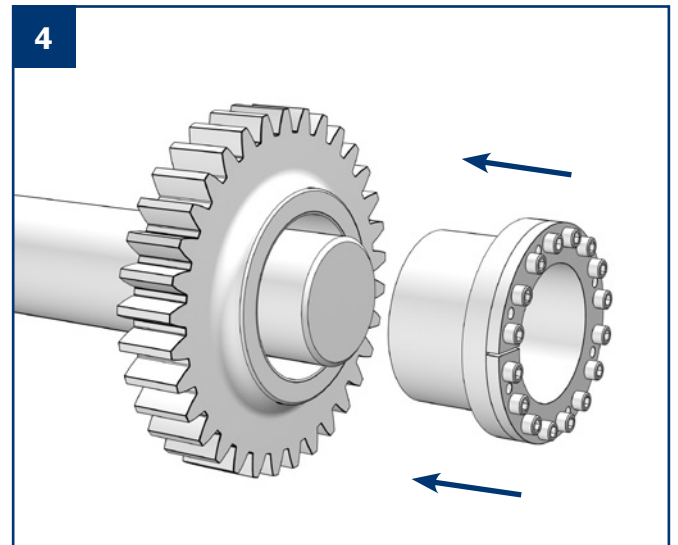
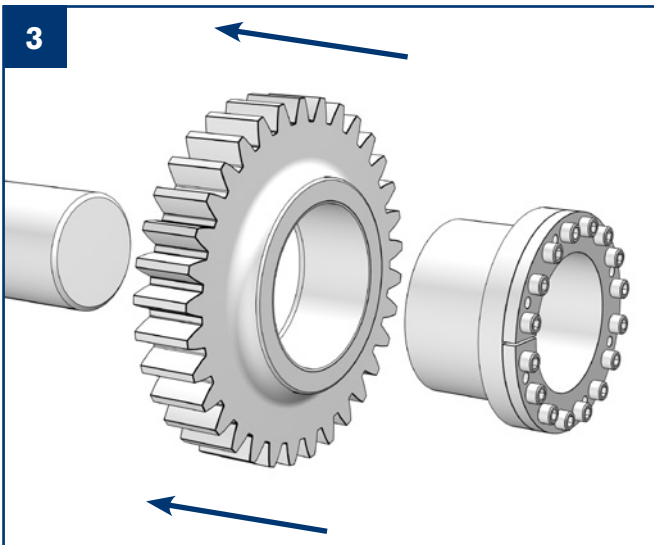
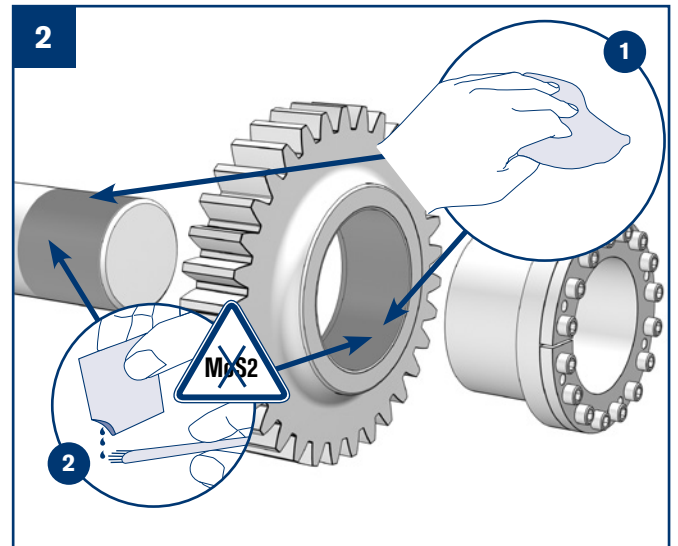
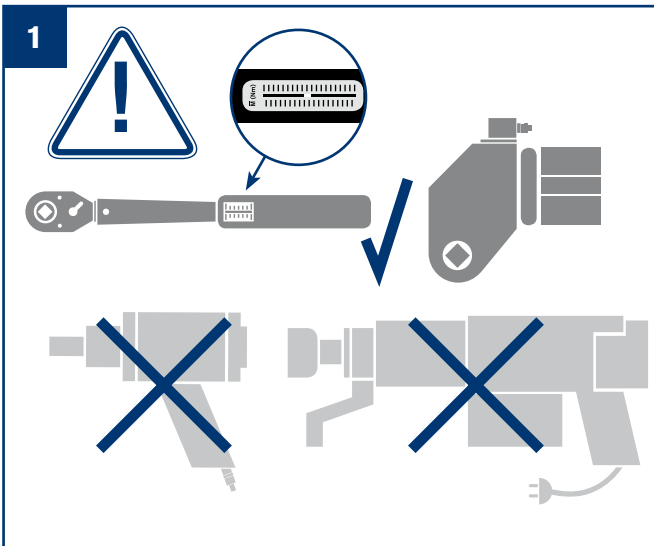

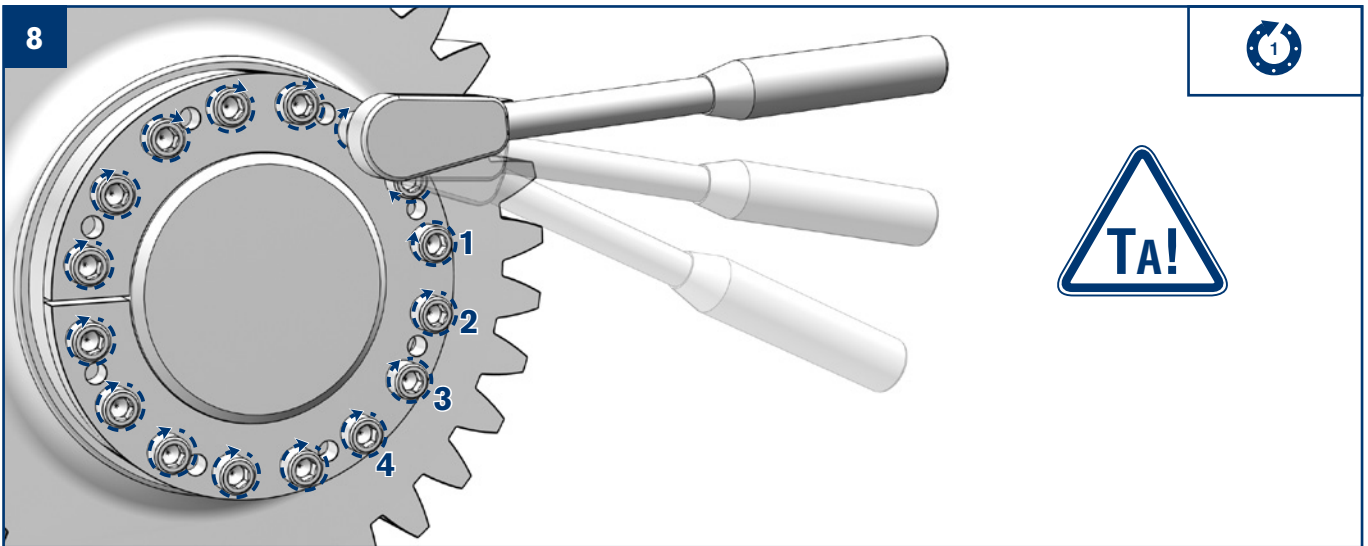
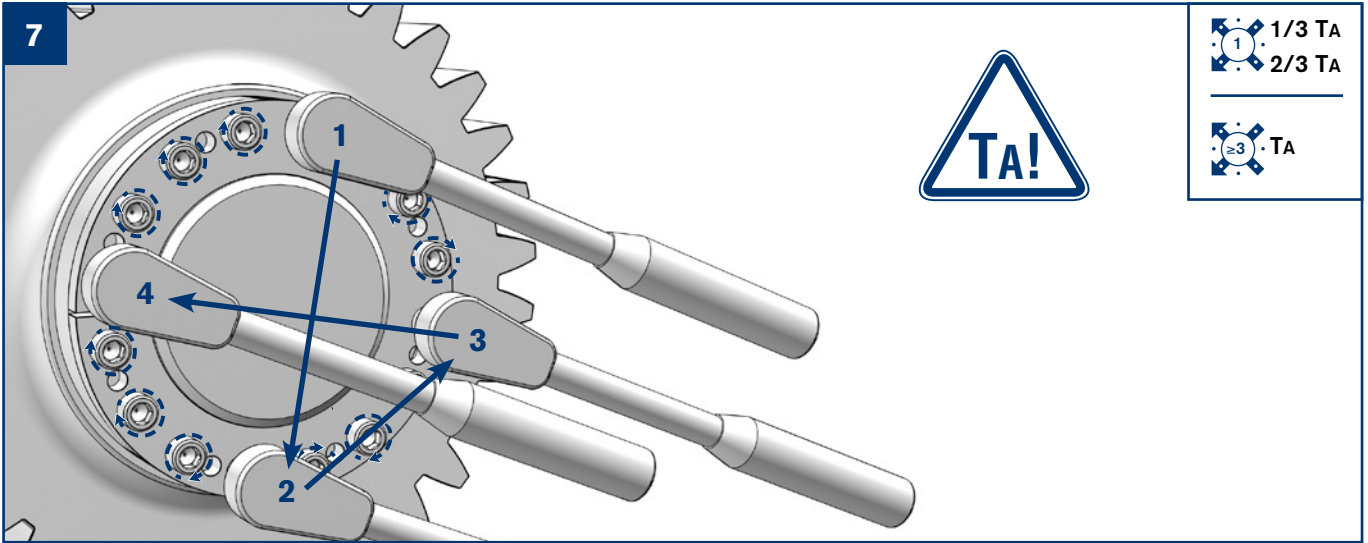

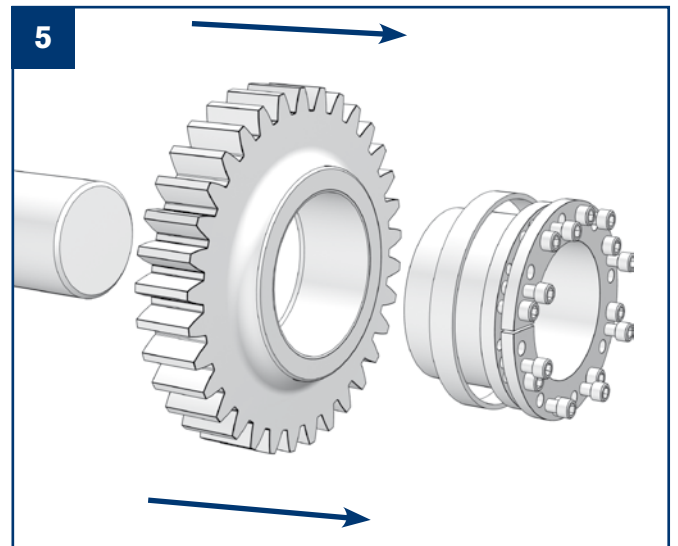
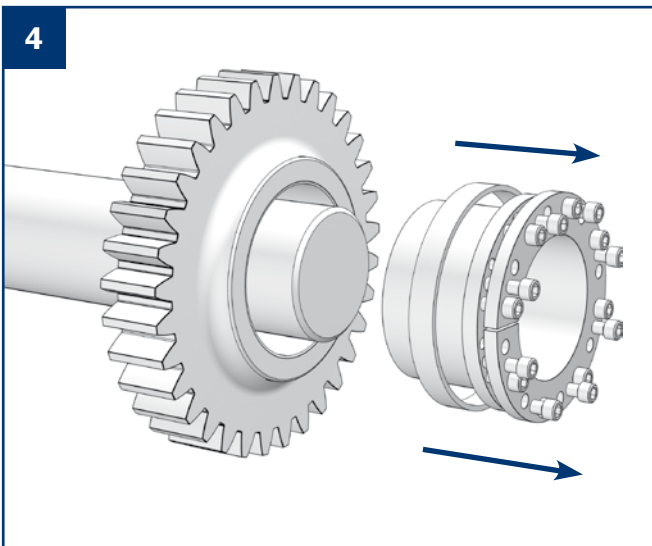
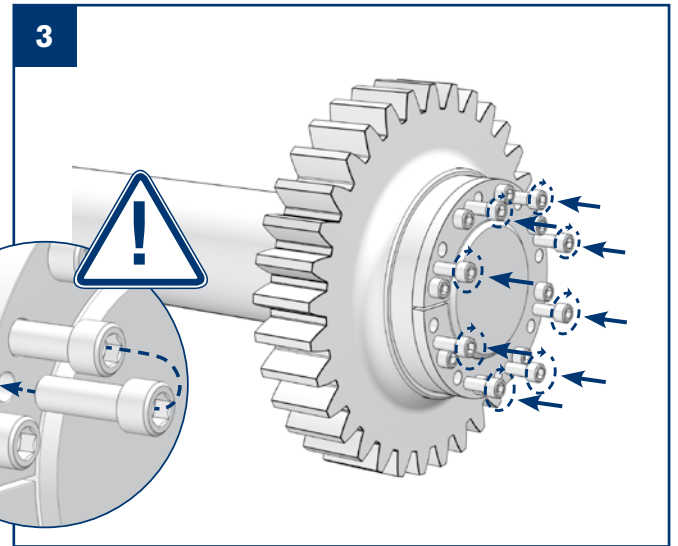
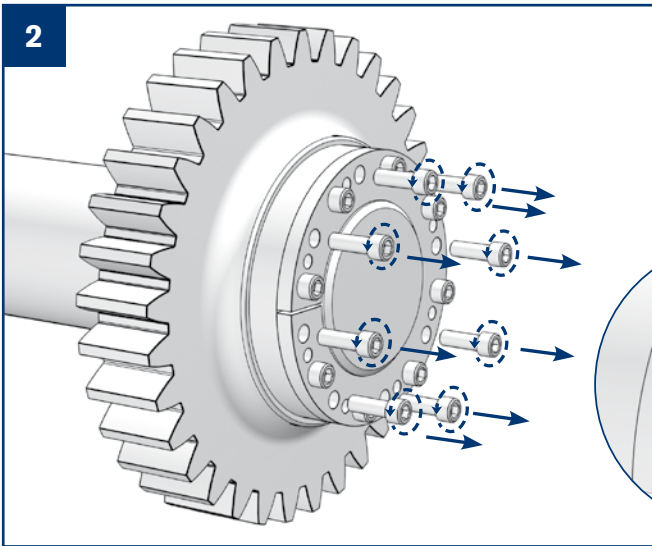
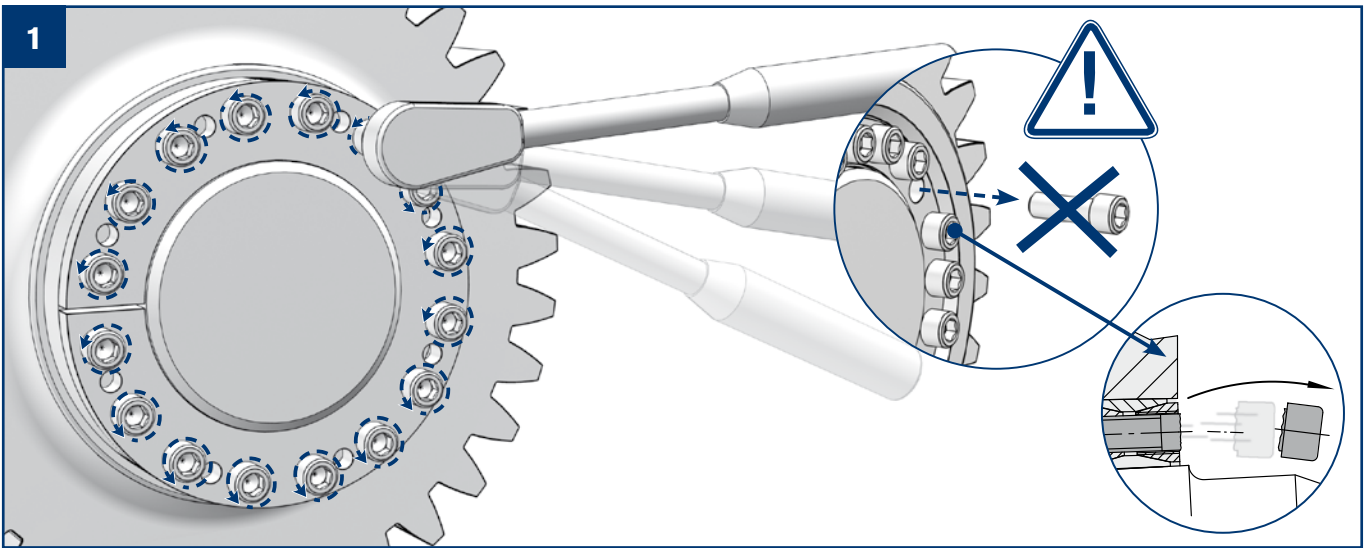

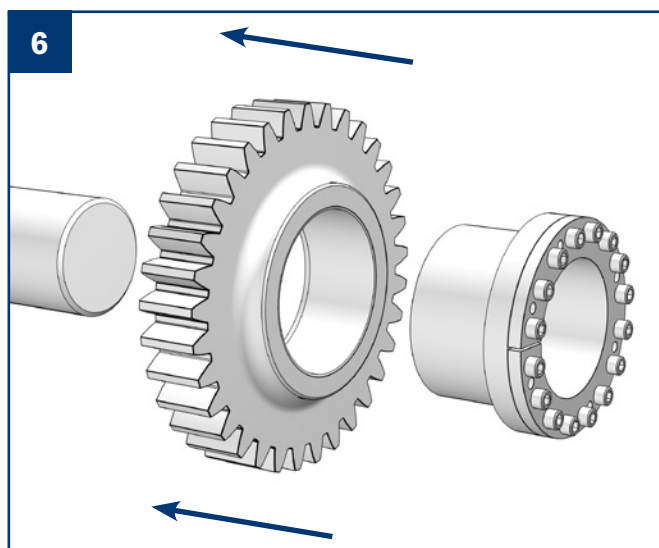
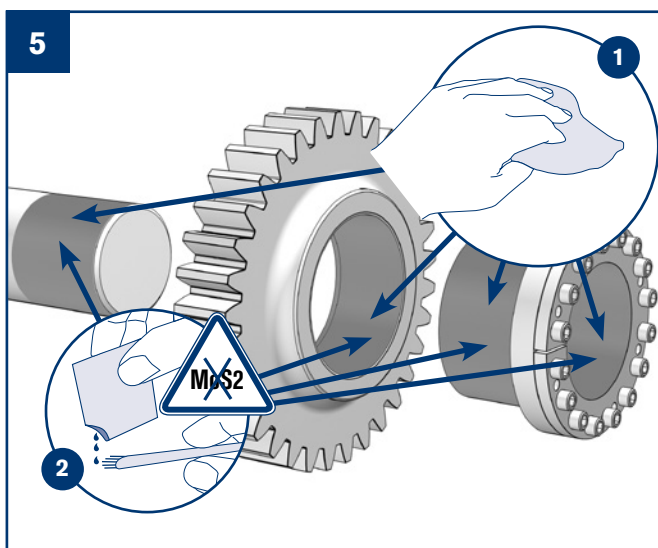
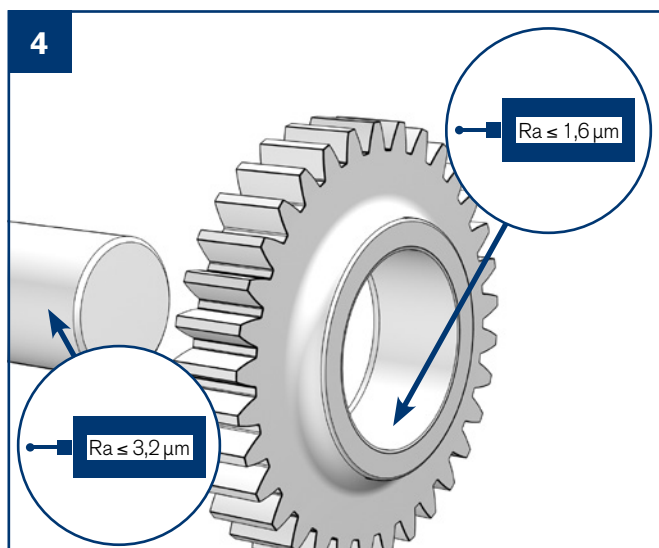
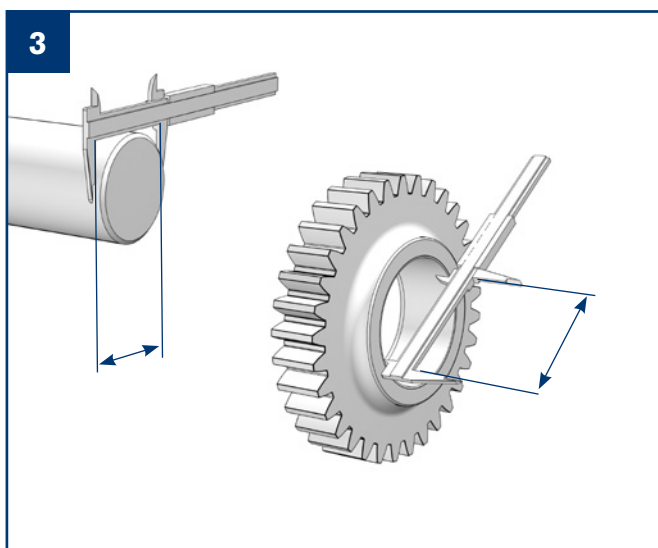
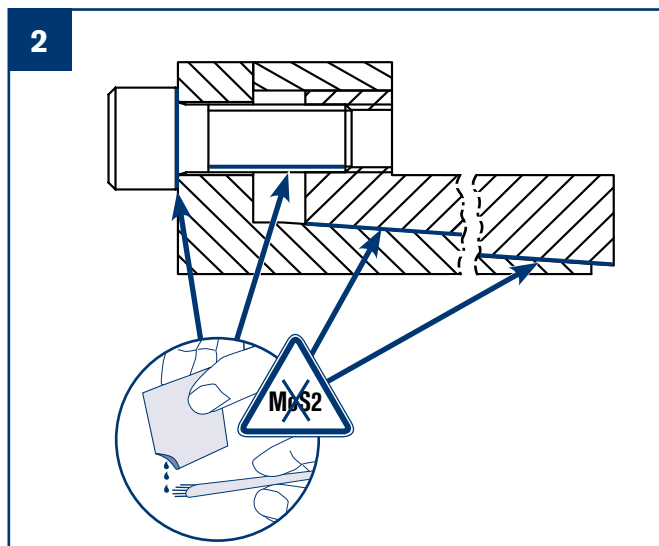
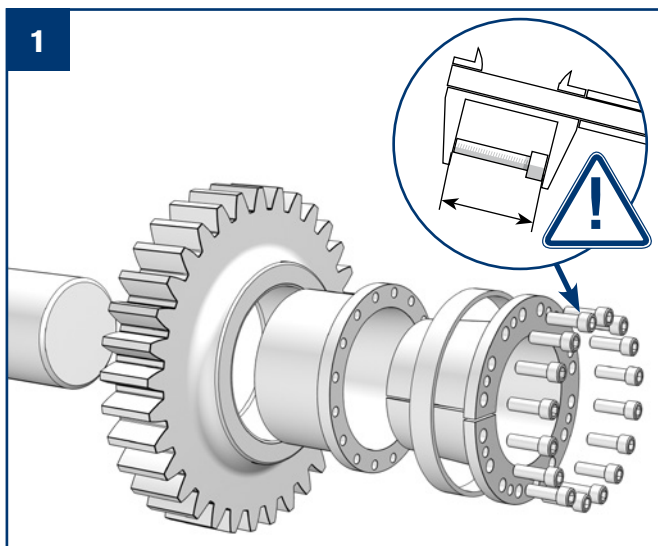

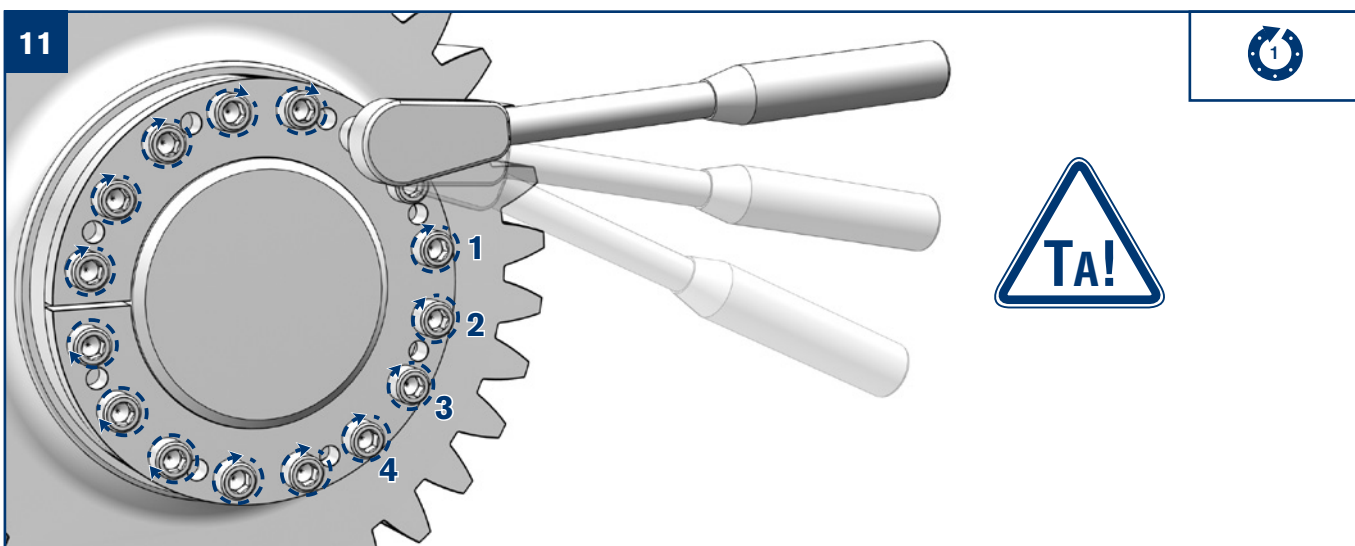
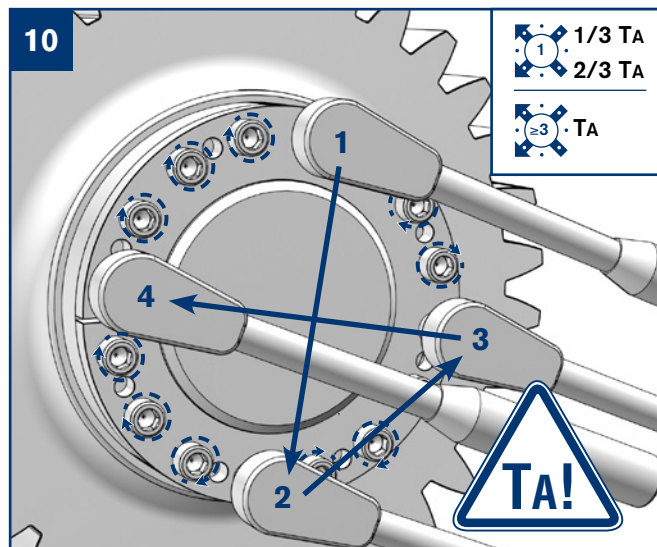
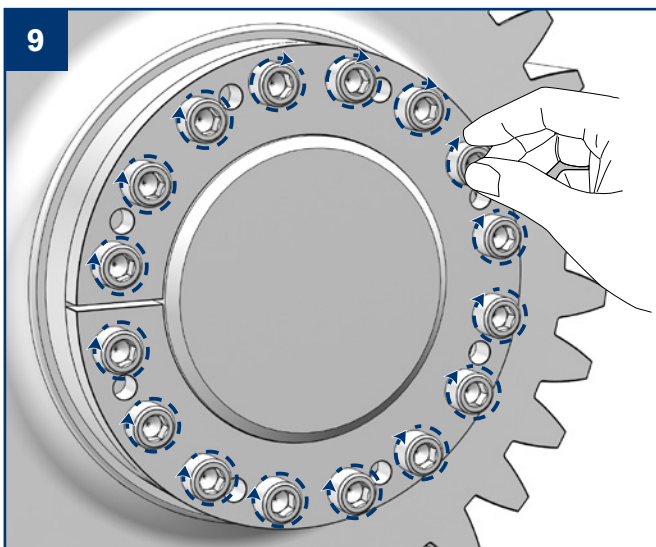
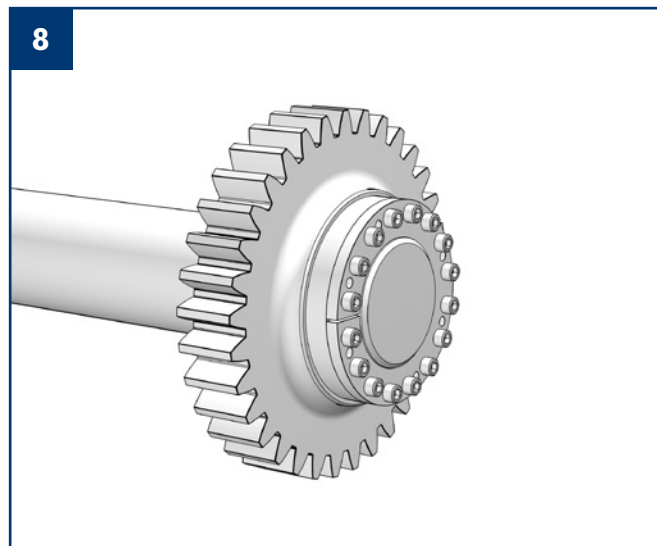
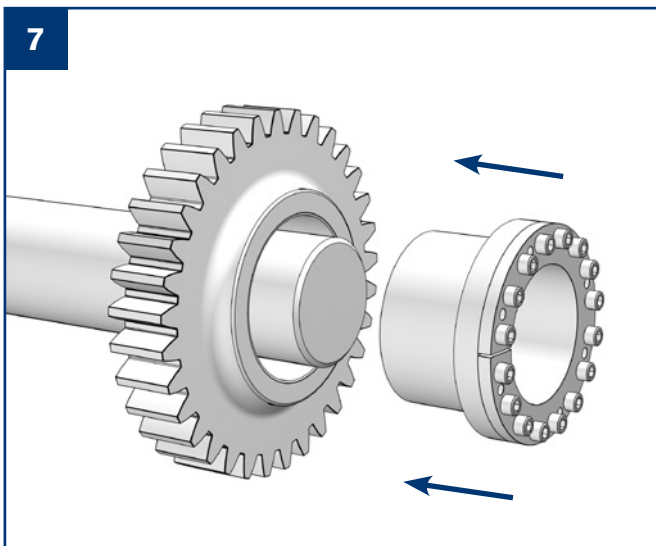

**RINGFEDER POWER TRANSMISSION GMBH**

Werner-Heisenberg-Straße 18, D-64823 Groß-Umstadt, Germany · Phone: +49 (0) 6078 9385-0 · Fax: +49 (0) 6078 9385-100  
E-mail: sales.international@ringfeder.com

**RINGFEDER POWER TRANSMISSION TSCHAN GMBH**

Zweibrücker Straße 104, D-66538 Neunkirchen, Germany · Phone: +49 (0) 6821 866-0 · Fax: +49 (0) 6821 866-4111  
E-mail: sales.tschan@ringfeder.com

**RINGFEDER POWER TRANSMISSION USA CORPORATION**

165 Carver Avenue, Westwood, NJ 07675, USA · Toll Free: +1 888 746-4333 · Phone: +1 201 666 3320 · Fax: +1 201 664 6053  
E-mail: sales.usa@ringfeder.com

**HENFEL INDÚSTRIA METALÚRGICA LTDA.**

Av. Major Hilário Tavares Pinheiro, 3447 · CEP 14871 300 · Jaboticabal - SP - Brazil · Phone: +55 (16) 3209-3422  
E-mail: vendas@henfel.com.br

**RINGFEDER POWER TRANSMISSION INDIA PRIVATE LIMITED**

Plot No. 4, Door No. 220, Mount - Poonamallee Road, Kattupakkam, Chennai – 600 056, India  
Phone: +91 (0) 44-2679 1411 · Fax: +91 (0) 44-2679 1422 · E-mail: sales.india@ringfeder.com

**KUNSHAN RINGFEDER POWER TRANSMISSION COMPANY LIMITED**

NO. 406 Jiande Road, Zhangpu 215321, Kunshan, Jiangsu Province, China  
Phone: +86 (0) 512-5745-3960 · Fax: +86 (0) 512-5745-3961 · E-mail: sales.china@ringfeder.com

Partner for Performance  
[www.ringfeder.com](http://www.ringfeder.com)

