

Installation, Removal, Maintaining Locking Assemblies

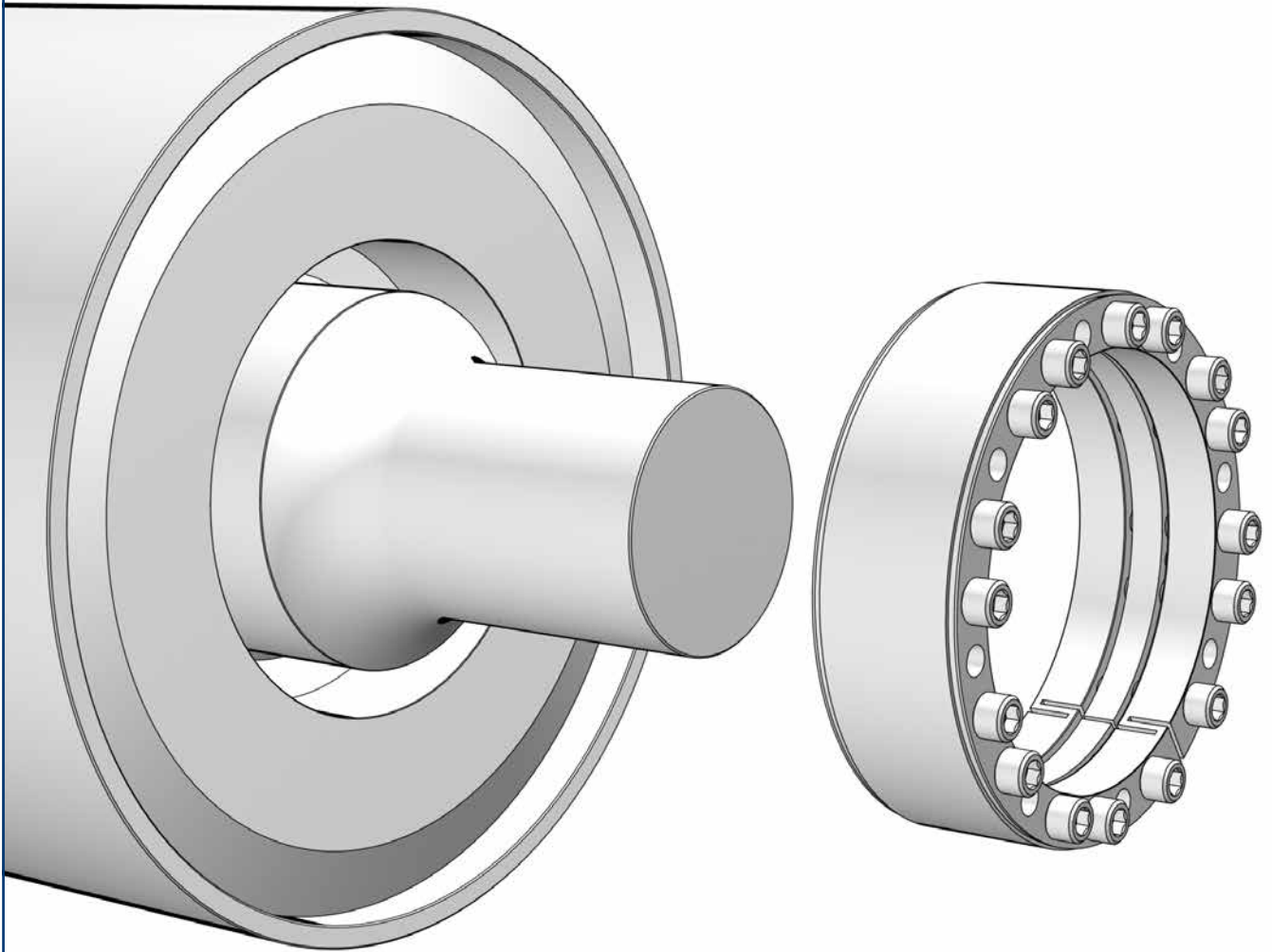

RfN 7515

EN

11|2016

Safety instructions

Rotating machine parts may injure operators and service staff!
Therefore:

- Switch off the drive before assembly work.
- Safeguard the machine against accidental switch-on.
- Mount all covers and protection devices before switching on the machine.
- RINGFEDER® products may only be mounted by specialist staff and for suitable applications.

Attention

- Study the assembly instructions thoroughly.
- Contravention of assembly or safety instructions will void all claims under warranty.
- RINGFEDER® reserves the right to technical changes to improve the product.
- RINGFEDER® locking assemblies are accepted state of the art.

For any questions or technical problems, please contact our technicians and engineers. See overleaf for contact details.

Used Lubricants

Designation	CAS number (ROHS):
Shell Omala 220 Gear / Bearing oil	-

Legend



Installation



Removal



Maintaining

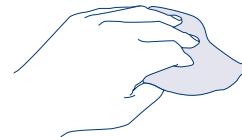

Cleaning



Oil hub and shaft lightly, if necessary (*do not use oil containing MoS2*).

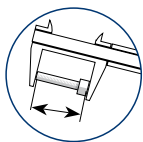

Check screw for deformation and replace, if necessary.



Repeat the described procedure cross-wise the specified number of times.



Repeat the described procedure as many times as specified.



Check for permissible peak-to-valley height.



Attention!
Absolutely observe!



Refer to the current locking assemblies catalogue for data on the required torques. Please check whether the manufacturer of the machine / plant has specified different torques.

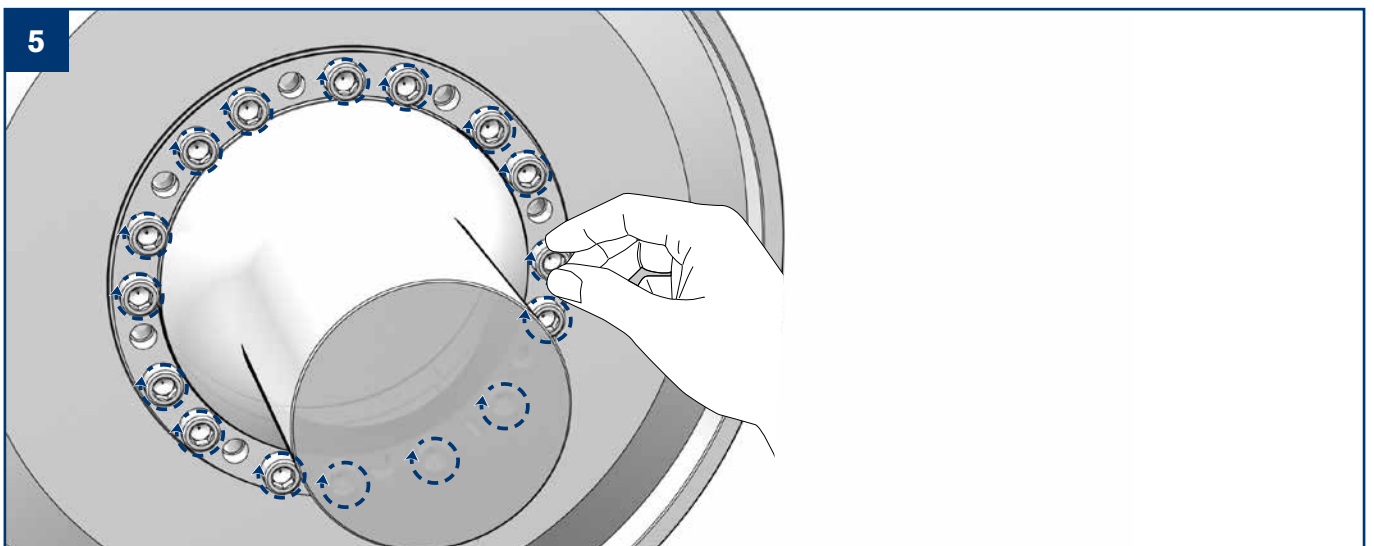
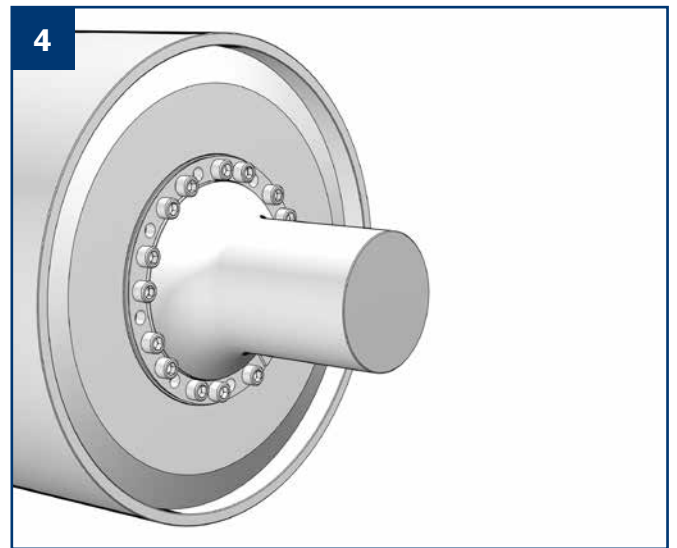
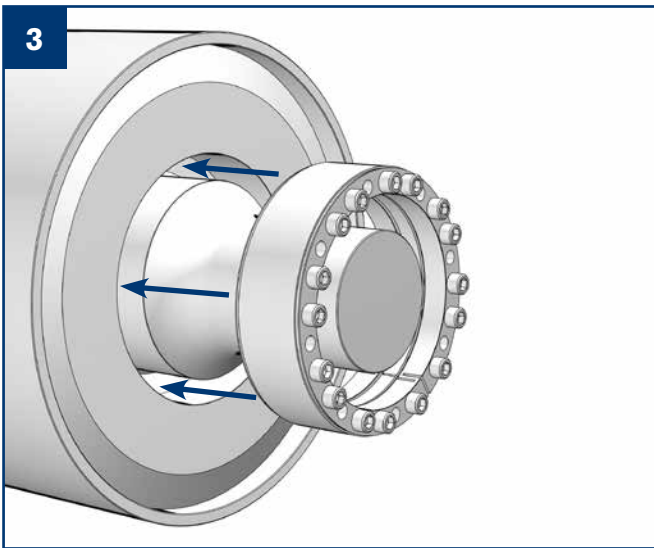
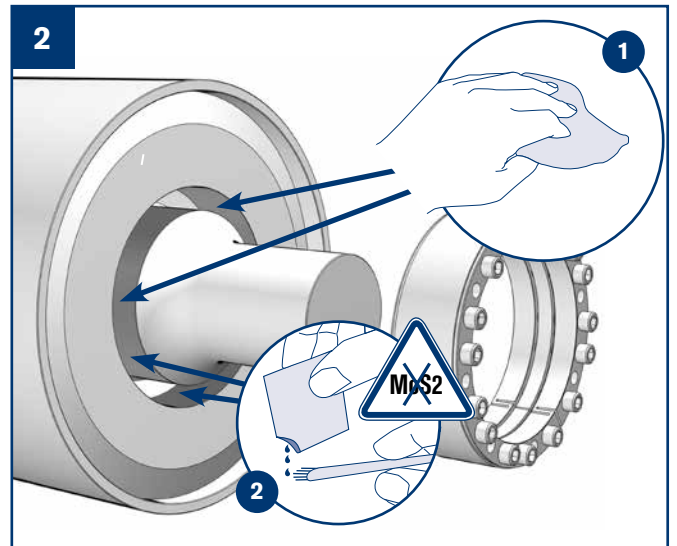
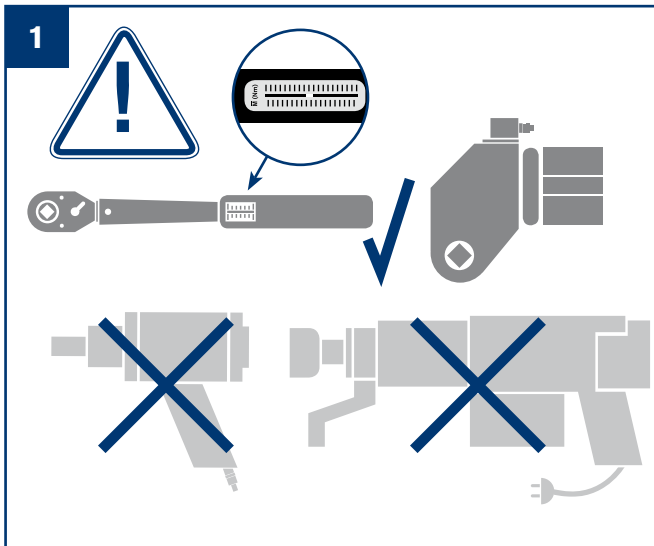

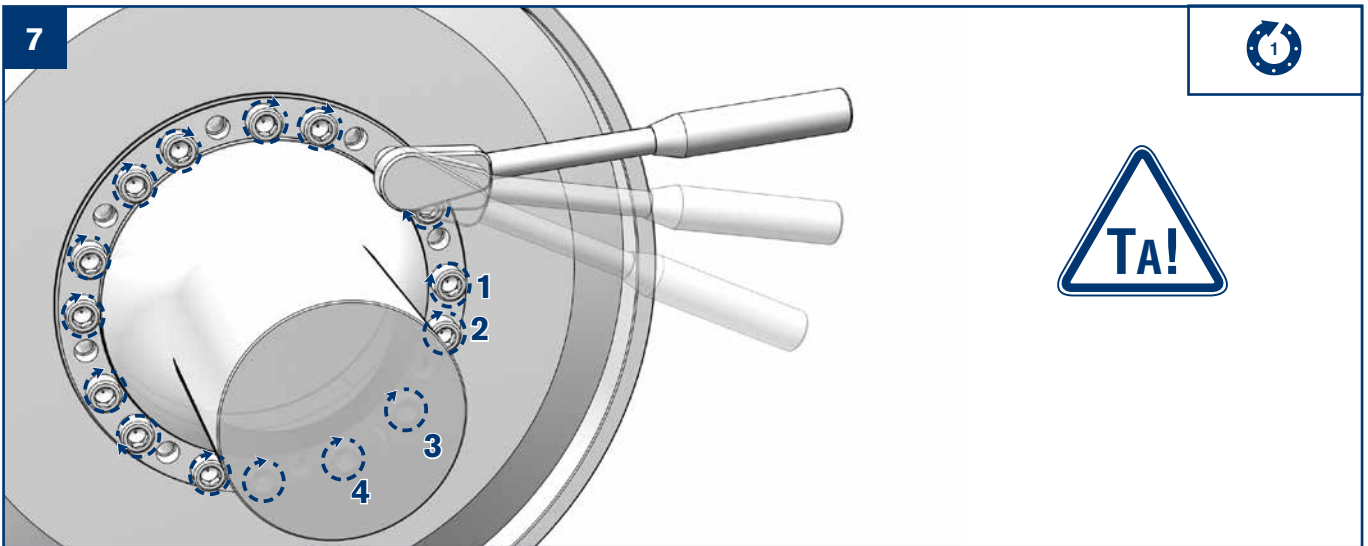
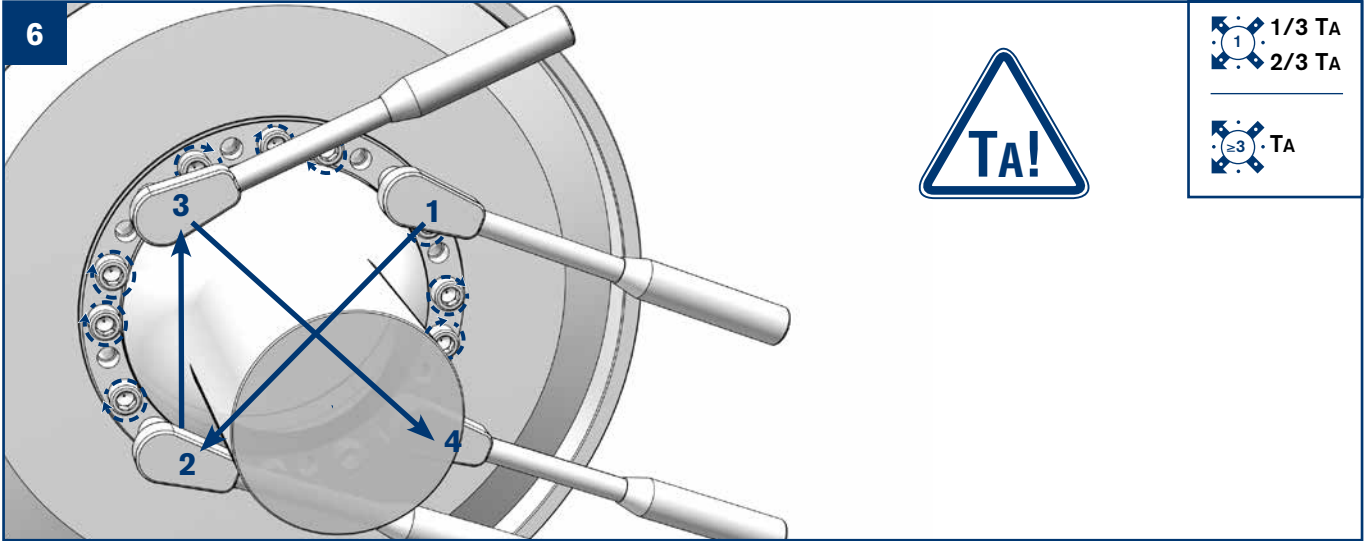

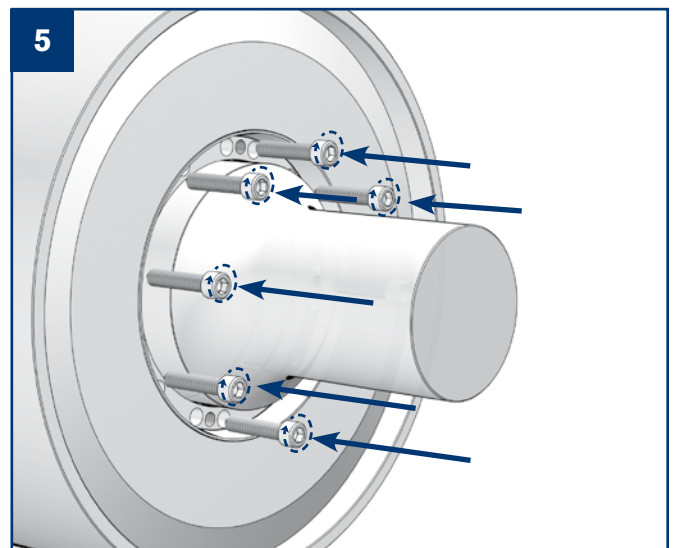
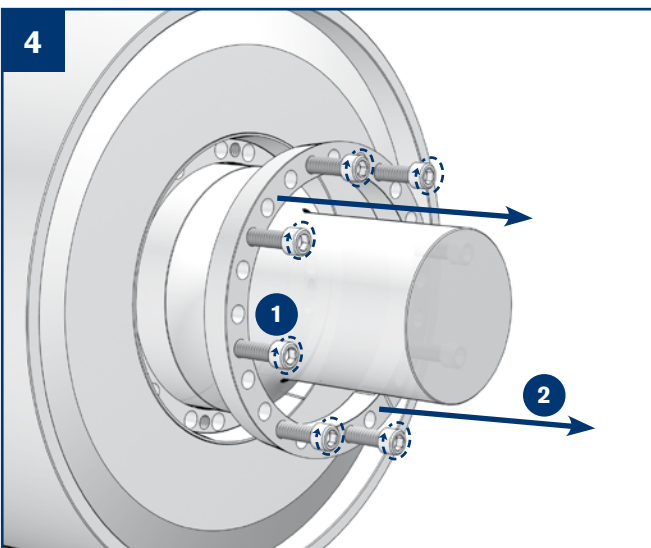
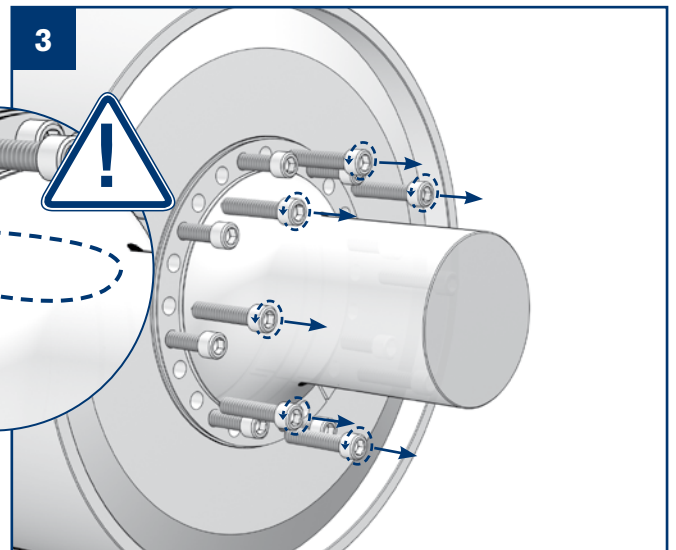
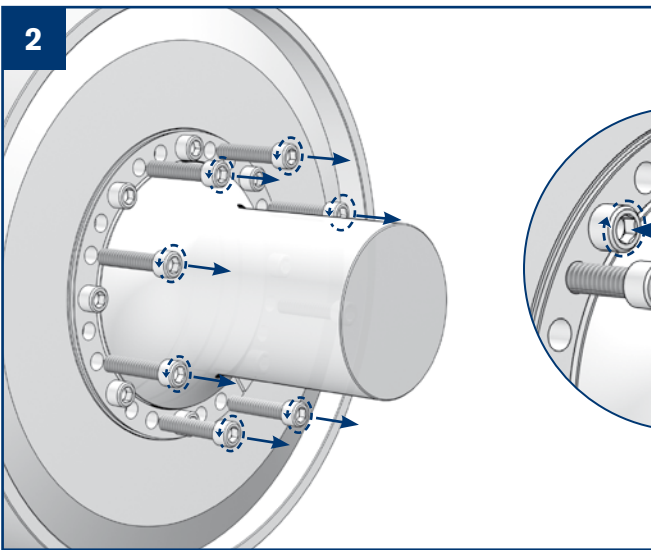
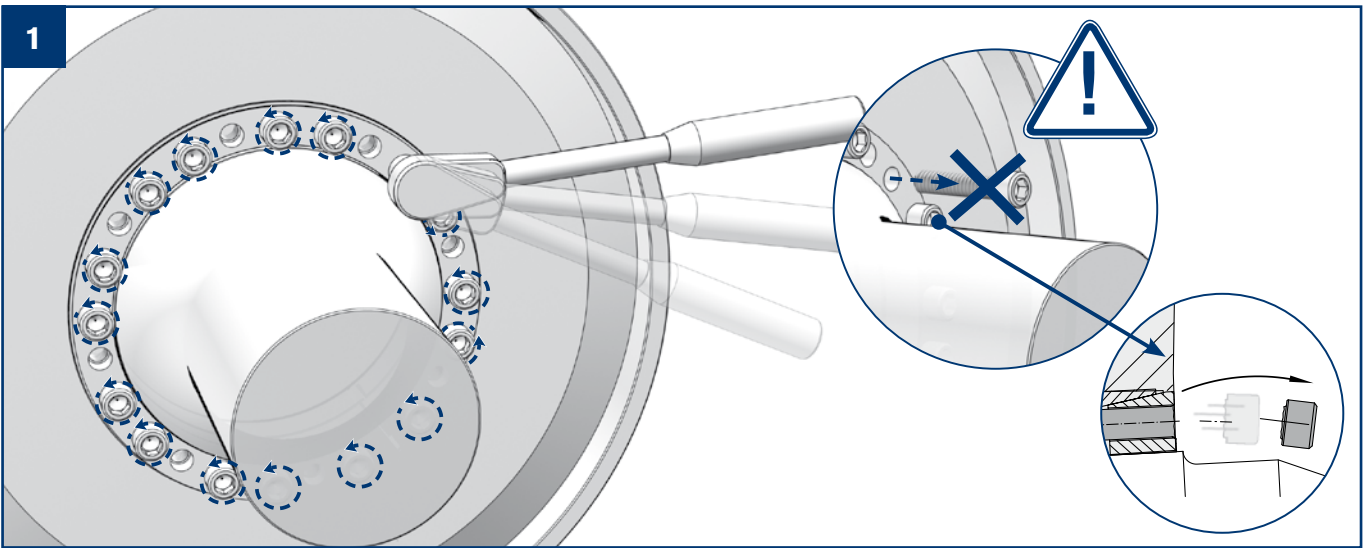

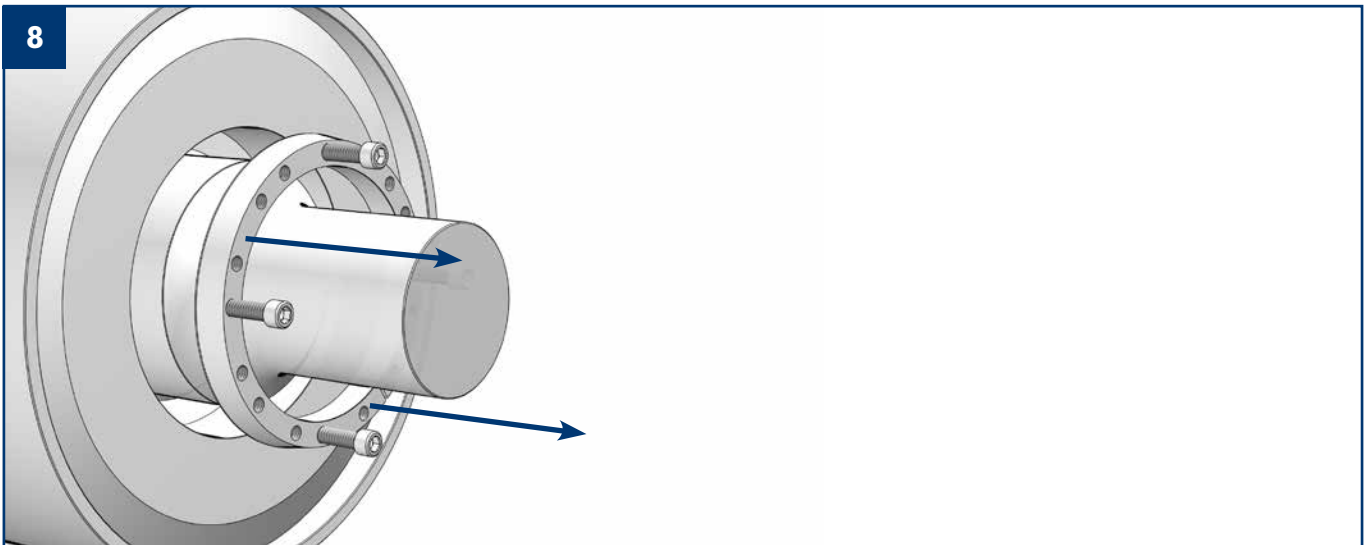
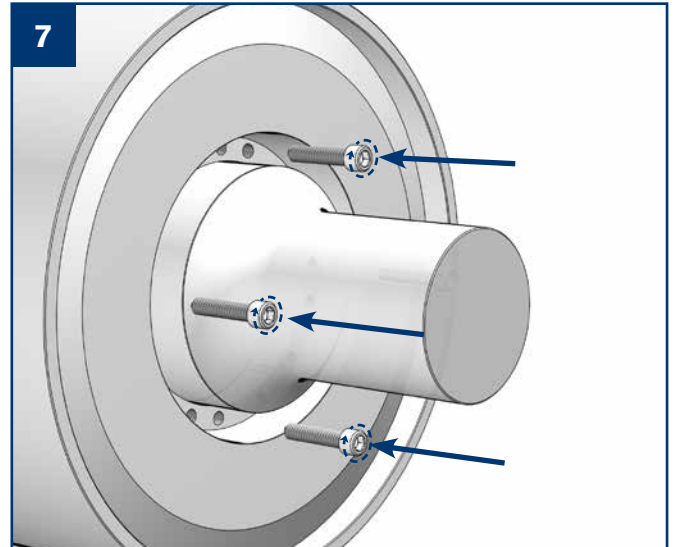
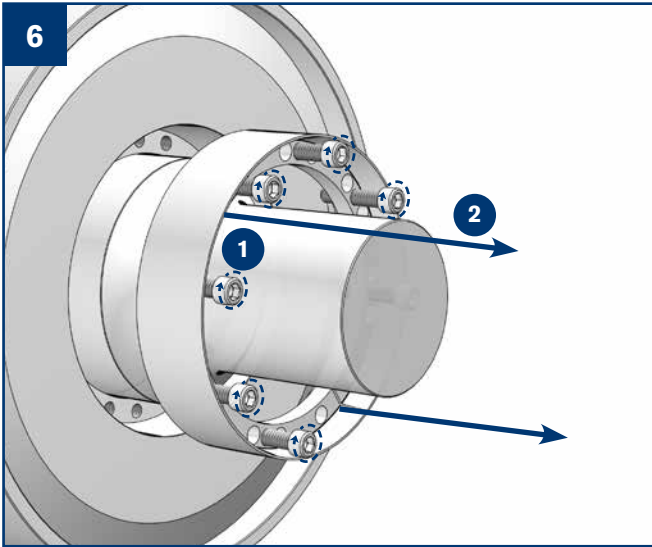

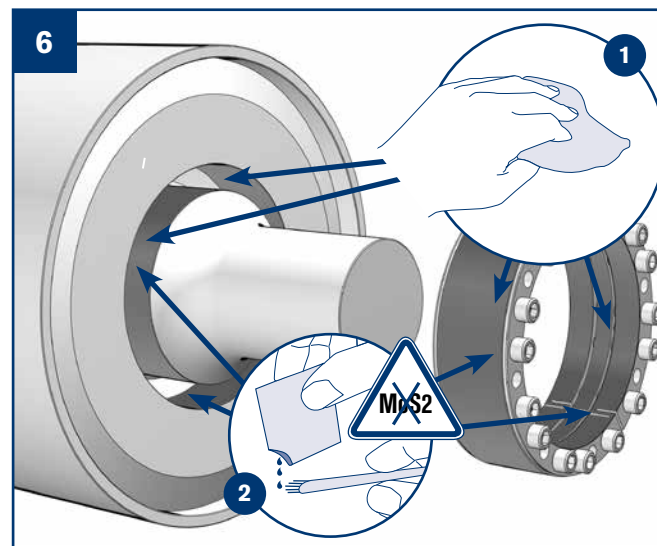
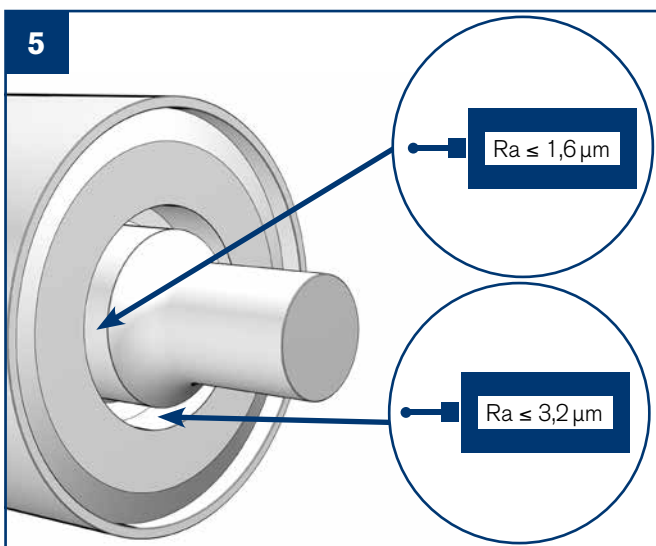
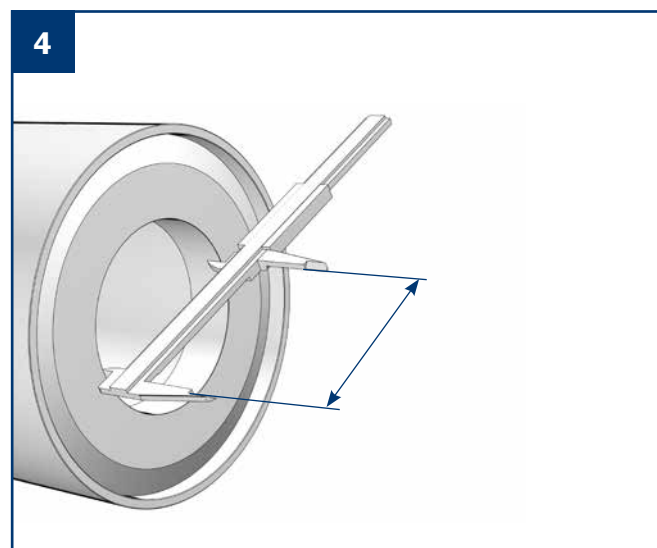
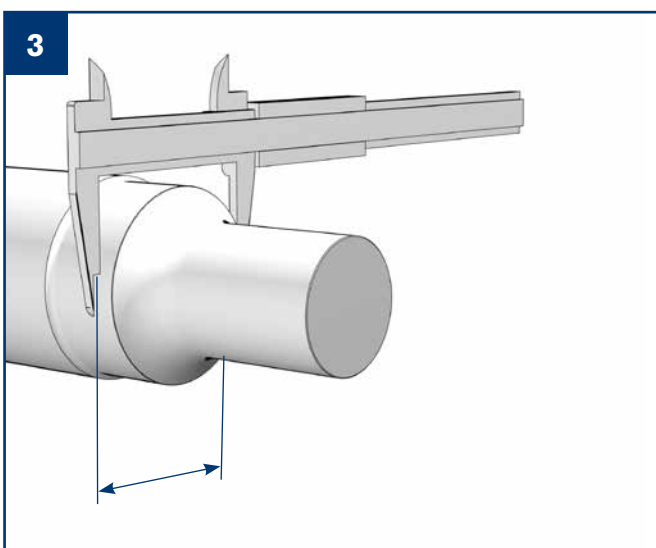
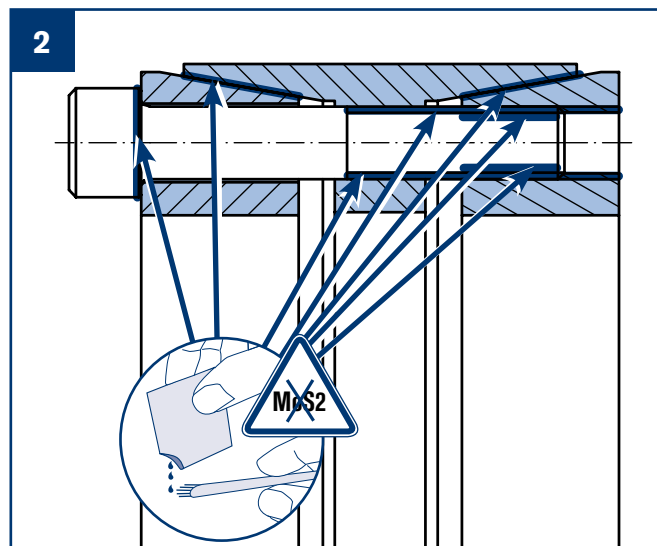
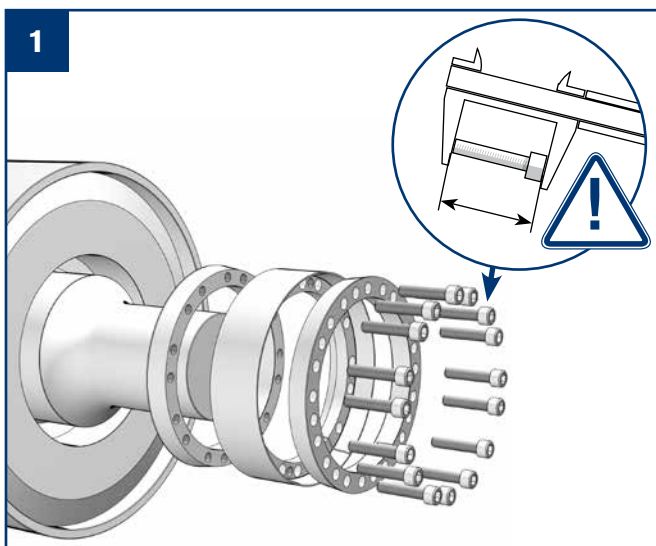

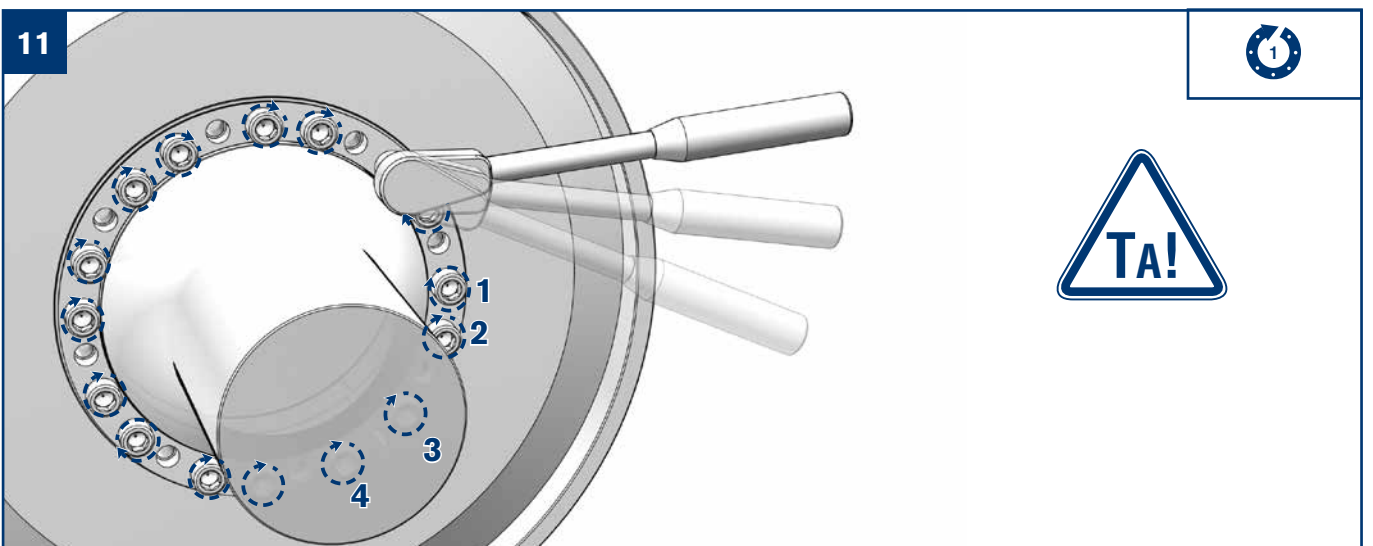
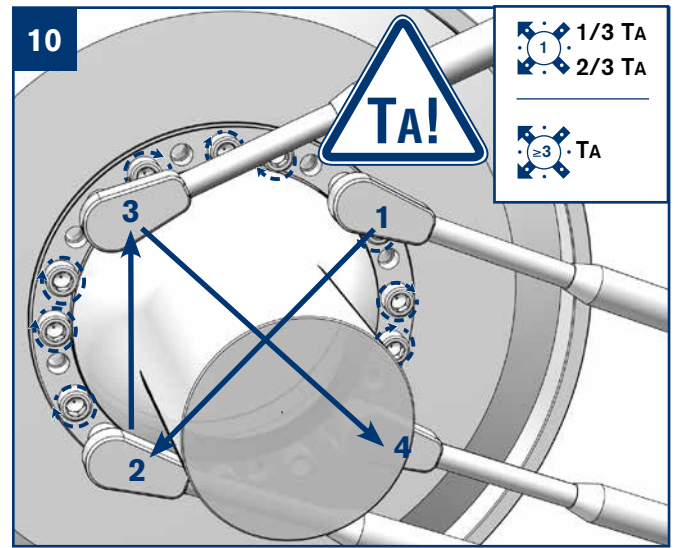
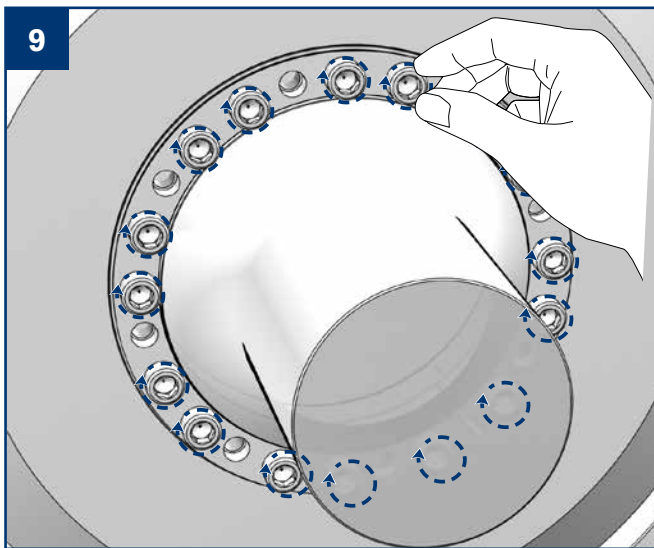
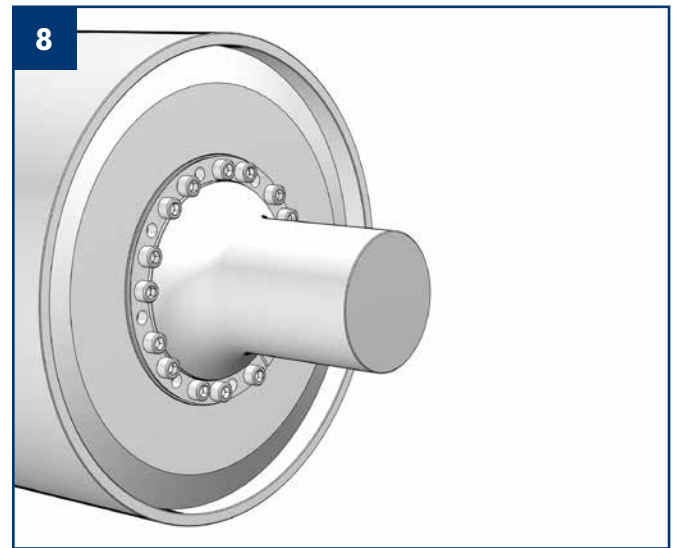
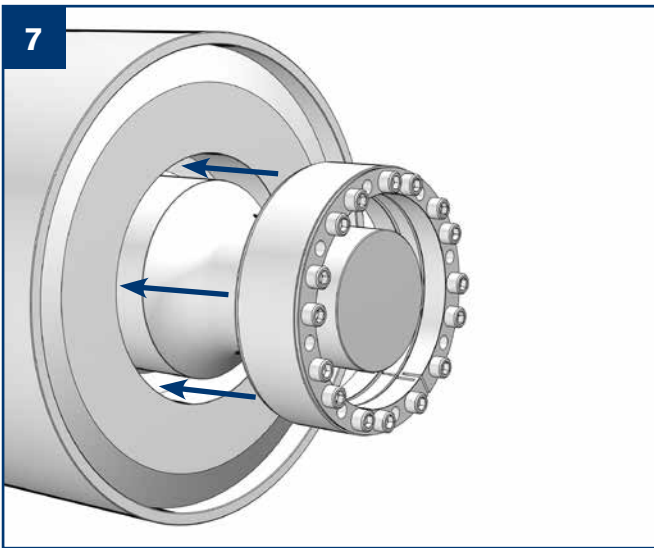

RINGFEDER POWER TRANSMISSION GMBH

Werner-Heisenberg-Straße 18, D-64823 Groß-Umstadt, Germany · Phone: +49 (0) 6078 9385-0 · Fax: +49 (0) 6078 9385-100
E-mail: sales.international@ringfeder.com

RINGFEDER POWER TRANSMISSION TSCHAN GMBH

Zweibrücker Straße 104, D-66538 Neunkirchen, Germany · Phone: +49 (0) 6821 866-0 · Fax: +49 (0) 6821 866-4111
E-mail: sales.tschan@ringfeder.com

RINGFEDER POWER TRANSMISSION USA CORPORATION

165 Carver Avenue, Westwood, NJ 07675, USA · Toll Free: +1 888 746-4333 · Phone: +1 201 666 3320 · Fax: +1 201 664 6053
E-mail: sales.usa@ringfeder.com

HENFEL INDÚSTRIA METALÚRGICA LTDA.

Av. Major Hilário Tavares Pinheiro, 3447 · Cer 14871 300 · Jaboticabal - SP - Brazil · Phone: +55 16 3209-3422
Fax: +55 16 3202-3563 · E-mail: vendas@henfel.com.br

RINGFEDER POWER TRANSMISSION INDIA PRIVATE LIMITED

Plot No. 4, Door No. 220, Mount - Poonamallee Road, Kattupakkam, Chennai – 600 056, India
Phone: +91 (0) 44-2679 1411 · Fax: +91 (0) 44-2679 1422 · E-mail: sales.india@ringfeder.com

KUNSHAN RINGFEDER POWER TRANSMISSION COMPANY LIMITED

No. 10 Dexin Road, Zhangpu Town 215321, Kunshan, China
Phone: +86 (0) 512-5745-3960 · Fax: +86 (0) 512-5745-3961 · E-mail: sales.china@ringfeder.com