

Locking Assemblies for Bending Loads

RINGFEDER® RfN 7012.2

Specially developed for use in belt drums

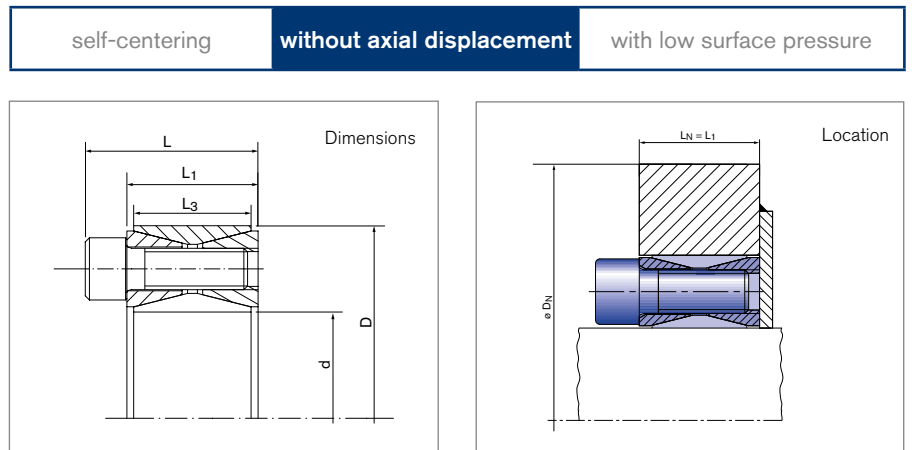

Locking Assembly dimensions				Locking screws														DN min at Rp0,2			Gw	
d	x D	L	L ₁	L ₃	n _{Sc}	D _G	T _{Ared}	T	F _{ax}	P _w	P _N	M _{Bmax}	P _{wmax} at M _{Bmax}	P _{Nmax} at M _{Bmax}	P _{wmin} at M _{Bmax}	P _{Nmin} at M _{Bmax}	T _{res} at M _{Bmax}	F _{ax} at M _{Bmax}	250	350		450
mm	mm	mm	mm	mm			Nm	Nm	kN	N/mm ²	N/mm ²	Nm	N/mm ²				Nm	kN	[N/mm ²]			kg
130	x 180	52	38	34	19	M12 x 35	125	19455	299	180	130	16400	359	259	0	0	10467	161	---	---	348	3,51
140	x 190	52	38	34	23	M12 x 35	125	25246	361	201	148	9700	299	221	103	76	23308	333	---	400	326	3,85
150	x 200	52	38	34	23	M12 x 35	125	26933	359	187	140	14690	326	244	48	36	22574	301	---	476	369	4,07
160	x 210	52	38	34	25	M12 x 35	125	31101	389	190	144	13380	308	235	71	54	28075	351	---	474	376	4,3
170	x 225	60	44	38	21	M14 x 40	190	36243	426	175	132	28080	350	265	0	0	22914	270	---	---	443	5,78
180	x 235	60	44	38	23	M14 x 40	190	41880	465	180	138	28860	350	268	11	8	30348	337	---	---	468	6,05
190	x 250	68	52	46	27	M14 x 45	190	51719	544	165	126	37000	312	237	19	14	36137	380	---	571	450	8,25
200	x 260	68	52	46	28	M14 x 45	190	56277	563	162	125	40180	314	241	11	8	39404	394	---	607	474	8,65
220	x 285	74	56	50	25	M16 x 50	295	74592	678	164	126	50440	313	241	14	11	54952	500	---	666	520	11,22
240	x 305	74	56	50	26	M16 x 50	295	84169	701	155	122	57100	310	244	0	0	61838	515	---	723	561	12,2
260	x 325	74	56	50	30	M16 x 50	295	104686	805	164	131	48910	287	229	42	33	92558	712	---	713	571	13,2
280	x 355	86,5	66	60	29	M18 x 60	405	131586	940	148	117	89170	297	234	0	0	96766	691	---	798	633	19,2
300	x 375	86,5	66	60	30	M18 x 60	405	145219	968	143	114	91850	285	228	0	0	112482	750	---	818	657	20,5
320	x 405	100,5	78	72	30	M20 x 70	580	201713	1261	145	115	139400	290	229	0	0	145793	911	---	889	712	29,6
340	x 425	100,5	78	72	31	M20 x 70	580	220626	1298	141	113	143500	281	225	0	0	167582	986	---	912	737	31,1
360	x 455	116	90	84	32	M22 x 80	780	293404	1630	143	113	178400	267	211	19	15	232936	1294	---	916	758	42,2
380	x 475	116	90	84	33	M22 x 80	780	318305	1675	139	111	204700	274	219	5	4	243754	1283	---	991	810	44
400	x 495	116	90	84	34	M22 x 80	780	344106	1721	136	110	217320	272	220	0	0	266798	1334	---	1035	845	46
420	x 515	116	90	84	37	M22 x 80	780	391995	1867	140	114	195820	257	210	24	19	339580	1617	---	1029	854	50
440	x 545	130	102	96	37	M24 x 90	1000	478752	2176	137	110	251950	248	200	26	21	407093	1850	---	1045	880	64,6
460	x 565	130	102	96	38	M24 x 90	1000	512615	2229	134	109	283500	254	206	14	12	427085	1857	---	1113	928	67,4
480	x 585	130	102	96	39	M24 x 90	1000	547520	2281	131	108	315100	259	212	4	3	447762	1866	---	1183	977	71
500	x 605	130	102	96	41	M24 x 90	1000	598054	2392	132	109	304200	250	207	14	12	514908	2060	---	1194	995	72,6
520	x 630	130	102	96	42	M24 x 90	1000	635586	2445	130	107	345050	259	214	1	1	533770	2053	---	1281	1056	80
540	x 650	130	102	96	43	M24 x 90	1000	674155	2497	128	106	355400	256	212	0	0	572866	2122	---	1314	1086	82
560	x 670	130	102	96	45	M24 x 90	1000	729980	2607	129	108	365700	255	213	2	2	631770	2256	---	1362	1123	85

To continue see next page

Locking Assemblies for Bending Loads RINGFEDER® RfN 7012.2

Locking Assembly dimensions					Locking screws				T	F _{ax}	p _w	p _N	M _b max	p _w max at M _b max	p _N max at M _b max	p _w min at M _b max	p _N min at M _b max	T _{res} at M _b max	F _{ax t} at M _b max	D _{N min} at R _{p0,2}			G _w
d	x D	L	L ₁	L ₃	n _{Sc}	D _G	T _{Ared}	250												350	450		
mm		mm					Nm	Nm	kN	N/mm ²	Nm	N/mm ²				Nm	kN	mm			kg		
580	x 690	130	102	96	47	M24 x 90	1000	787923	2717	129	109	354800	248	209	11	9	703519	2426	---	1372	1141	88	
600	x 710	130	102	96	48	M24 x 90	1000	830673	2769	128	108	386400	253	213	3	2	735331	2451	---	1443	1190	91	
620	x 730	130	102	96	49	M24 x 90	1000	874450	2821	126	107	401500	251	214	0	0	776828	2506	---	1484	1224	93	
640	x 750	130	102	96	52	M24 x 90	1000	956024	2988	129	110	364600	240	204	18	16	883770	2762	---	1465	1225	96	
660	x 770	130	102	96	54	M24 x 90	1000	1021852	3097	130	111	353700	234	200	26	22	958686	2905	---	1477	1244	99	
680	x 790	130	102	96	54	M24 x 90	1000	1050855	3091	126	108	357760	228	196	23	20	988081	2906	---	1489	1261	102	
700	x 810	130	102	96	54	M24 x 90	1000	1079804	3085	122	105	357770	221	191	23	20	1018812	2911	---	1495	1275	104	
720	x 830	130	102	96	54	M24 x 90	1000	1108702	3080	118	103	354670	214	185	23	20	1050443	2918	---	1498	1287	107	
740	x 850	130	102	96	56	M24 x 90	1000	1179681	3188	119	104	367670	215	188	23	20	1120922	3030	---	1548	1326	110	
760	x 870	130	102	96	58	M24 x 90	1000	1252745	3297	120	105	379250	217	189	23	20	1193960	3142	---	1595	1363	113	
780	x 890	130	102	96	59	M24 x 90	1000	1305758	3348	119	104	385650	215	188	23	20	1247509	3199	---	1623	1390	116	
800	x 910	130	102	96	60	M24 x 90	1000	1359784	3399	117	103	392150	213	187	22	20	1302011	3255	---	1652	1417	118	

More sizes on request

Explanations

d = Inner diameter	p_w = Surface pressure on shaft at given T _A	T_{res} at M_bmax = Remaining transmissible torque at indicated Mbmax and specified torque
D = Outer diameter	p_N = Surface pressure on hub at given T _A	F_{ax} at M_bmax = Transmissible axial force at max. bending moment
L = Overall length	M_bmax = Max. bending moment under the specified T _A	D_{N min} at R_{p0,2} = Min. hub outer diameter depending of the given hub yield point R _{p0,2} and part of bending moment
L₁ = Overall length (without screws)	p_wmax at M_bmax = Max. surface pressure on shaft at max. bending moment	G_w = Weight
L₃ = Width of ring	p_Nmax at M_bmax = Max. surface pressure on hub at max. bending moment	
n_{Sc} = Quantity of screws	p_wmin at M_bmax = Min. surface pressure on shaft at max. bending moment	
D_G = Thread	p_Nmin at M_bmax = Min. surface pressure on hub at max. bending moment	
T_{Ared} = Reduced tightened torque of the screws under bending load		
T = Transmissible torque at given T _A		
F_{ax} = Transmissible axial force		

Ordering example

Locking Assembly	d	D
RfN 7012.2	200	260

Technical Information

- Surface finishes: Shaft and hub bores R_a ≤ 3,2 μm
- Tolerances: Shaft: h9 · Hub: H9

Remark: The Values of the shaft- and hub pressures have been calculated with the screw tightening shown in the tables. Increase resp. reduction of the screw tightening torque results in different calculation values!

The specified pressures at M_bmax. are sometimes very low. An operation near these limit values may therefore lead to increased fretting corrosion! More options with reduced bending moments (M_b 20% - M_b 80%) are also available.

Further information on
RINGFEDER® RfN 7012.2
 for Bending Loads
 on www.ringfeder.com

Disclaimer of liability

All technical details and notes are non-binding and cannot be used as a basis for legal claims. The user is obligated to determine whether the represented products meet his requirements. We reserve the right carry out modifications at any time in the interests of technical progress.