

# Locking Assemblies for Bending Loads

## RINGFEDER® RfN 7015.0

Transfer of bending moments possible, highest torque and/or axial forces, excellent concentricity



self-centering      without axial displacement      with low surface pressure

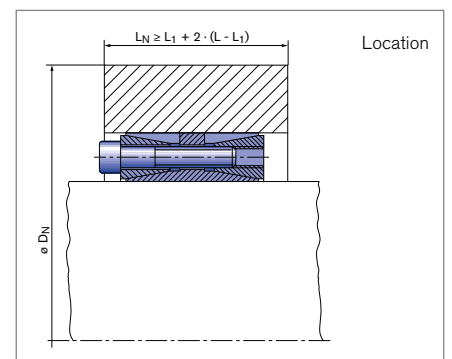
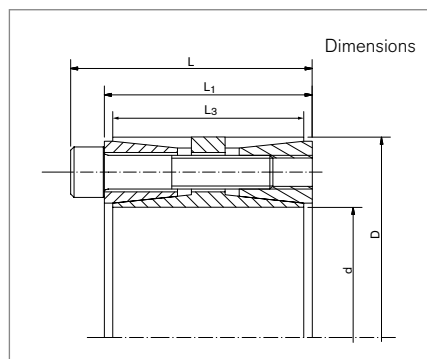

Locking Assembly dimensions				Locking screws													D <sub>N min</sub> at R <sub>p0,2</sub>			G <sub>w</sub>			
d	x	D	L	L <sub>1</sub>	L <sub>3</sub>	n <sub>Sc</sub>	D <sub>G</sub>	T <sub>Ared</sub>	T	F <sub>ax</sub>	P <sub>w</sub>	P <sub>N</sub>	M <sub>Bmax</sub>	P <sub>wmax</sub> at M <sub>Bmax</sub>	P <sub>Nmax</sub> at M <sub>Bmax</sub>	P <sub>wmin</sub> at M <sub>Bmax</sub>	P <sub>Nmin</sub> at M <sub>Bmax</sub>	T <sub>res</sub> at M <sub>Bmax</sub>	F <sub>ax</sub> at M <sub>Bmax</sub>		250	350	450
mm				mm				Nm	Nm	kN	N/mm <sup>2</sup>			N/mm <sup>2</sup>				Nm	kN	mm			kg
100	x	145	77	65	60	10	M12 x 55	115	11297	226	157	108	11200	215	148	98	68	1474	29	258	215	198	4,1
110	x	155	77	65	60	10	M12 x 55	115	12426	226	142	101	12300	201	143	84	60	1767	32	266	225	209	4,4
120	x	165	77	65	60	12	M12 x 55	115	16267	271	157	114	16100	227	165	87	63	2326	39	333	261	236	4,8
130	x	180	86	74	68	15	M12 x 60	115	22028	339	156	113	21900	224	162	89	64	2375	37	361	283	257	6,5
140	x	190	86	74	68	18	M12 x 60	115	28468	407	174	128	21600	236	174	113	83	18543	265	430	315	281	7
150	x	200	86	74	68	18	M12 x 60	115	30501	407	163	122	30300	224	183	82	61	3495	47	---	346	305	7,4
160	x	210	86	74	68	21	M12 x 60	115	37957	474	178	136	22500	234	179	122	93	30569	382	501	356	315	7,8
170	x	225	95	81	75	18	M14 x 65	185	47955	564	179	135	33300	244	184	114	86	34508	406	---	391	344	10
180	x	235	95	81	75	18	M14 x 65	185	50776	564	169	129	49800	260	199	77	59	9909	110	---	445	379	10,6
190	x	250	108	94	88	20	M14 x 75	185	59552	627	149	113	58300	224	170	74	57	12149	128	574	417	372	14,3
200	x	260	108	94	88	24	M14 x 75	185	75224	752	170	131	30900	208	160	132	102	68585	686	535	414	374	15
220	x	285	120	104	98	18	M16 x 90	285	84791	771	152	117	84300	230	178	74	57	9107	83	---	495	435	19,8
240	x	305	120	104	98	24	M16 x 90	285	123332	1028	186	146	52500	230	181	141	111	111599	930	---	540	471	21,4
260	x	325	120	104	98	25	M16 x 90	285	139176	1071	178	143	51900	219	175	138	110	129137	993	801	558	492	23
280	x	355	144	126	120	24	M18 x 110	390	174092	1244	161	127	124600	223	176	99	78	121585	868	---	624	545	35,2
300	x	375	144	126	120	25	M18 x 110	390	194299	1295	157	125	139200	222	177	92	73	135556	904	---	663	578	37,4
320	x	405	162	142	135	25	M20 x 120	550	265703	1661	159	125	171300	216	171	101	80	203112	1269	986	692	611	51,3
340	x	425	162	142	135	25	M20 x 120	550	282310	1661	149	120	229800	222	178	77	61	163984	965	---	753	656	54,1
360	x	455	187	165	158	25	M22 x 130	745	371148	2062	149	118	295300	214	169	84	66	224830	1249	1118	780	688	75,4
380	x	475	187	165	158	25	M22 x 130	745	391767	2062	141	113	389800	223	178	60	48	39211	206	---	854	741	79
400	x	495	187	165	158	25	M22 x 130	745	412387	2062	134	108	410300	215	174	53	43	41431	207	---	870	761	82,8
420	x	515	187	165	158	30	M22 x 130	745	519607	2474	153	125	311300	212	173	94	77	416033	1981	---	900	788	86,5
440	x	545	204	180	172	30	M24 x 150	960	639702	2908	154	124	417000	216	175	91	74	485108	2205	---	960	839	110
460	x	565	204	180	172	30	M24 x 150	960	668779	2908	147	120	485800	217	177	77	63	459635	1998	---	1006	875	114
480	x	585	204	180	172	32	M24 x 150	960	744381	3102	150	123	446100	212	174	89	73	595900	2483	---	1025	897	119
500	x	605	204	180	172	32	M24 x 150	960	775396	3102	144	119	474800	207	171	82	68	613029	2452	---	1045	919	123

To continue see next page

### Locking Assemblies for Bending Loads RINGFEDER® RfN 7015.0

Locking Assembly dimensions			Locking screws			T	F <sub>ax</sub>	P <sub>w</sub>	P <sub>N</sub>	M <sub>bmax</sub>	P <sub>wmax</sub> at M <sub>bmax</sub>	P <sub>Nmax</sub> at M <sub>bmax</sub>	P <sub>wmin</sub> at M <sub>bmax</sub>	P <sub>Nmin</sub> at M <sub>bmax</sub>	T <sub>res</sub> at M <sub>bmax</sub>	F <sub>ax</sub> at M <sub>bmax</sub>	D <sub>N min</sub> at R <sub>p0,2</sub>			G <sub>w</sub>			
d	x	D	L	L <sub>1</sub>	L <sub>3</sub>												n <sub>Sc</sub>	D <sub>G</sub>	T <sub>Ared</sub>		250	350	450
mm			mm			Nm	kN	N/mm <sup>2</sup>	Nm	N/mm <sup>2</sup>				Nm	kN	mm			kg				
520	x	630	227	200	190	30	M27 x 160	1440	1014357	3901	156	129	613500	219	181	93	77	807798	3107	---	1140	986	148
540	x	650	227	200	190	30	M27 x 160	1440	1053370	3901	150	125	674900	217	180	84	69	808764	2995	---	1172	1015	154
560	x	670	227	200	190	30	M27 x 160	1440	1092384	3901	145	121	684200	210	176	80	67	851571	3041	---	1177	1029	160
580	x	690	227	200	190	30	M27 x 160	1440	1131398	3901	140	118	890500	222	186	58	49	697904	2407	---	1292	1103	165
600	x	710	227	200	190	32	M27 x 160	1440	1248439	4161	144	122	798300	215	182	73	62	959853	3200	---	1293	1116	170
620	x	730	227	200	190	32	M27 x 160	1440	1290054	4161	140	119	1004600	226	192	53	45	809331	2611	---	1417	1193	177
640	x	750	227	200	190	35	M27 x 160	1440	1456512	4552	148	126	651400	202	173	94	80	1302730	4071	---	1296	1139	182
660	x	770	227	200	190	35	M27 x 160	1440	1502028	4552	143	123	772500	206	176	81	69	1288151	3903	---	1359	1186	187
680	x	790	227	200	190	36	M27 x 160	1440	1591760	4682	143	123	435600	177	153	109	94	1530997	4503	1579	1239	1124	193
700	x	810	227	200	190	36	M27 x 160	1440	1638576	4682	139	120	641900	188	163	90	78	1507613	4307	1789	1329	1189	198
720	x	830	227	200	190	40	M27 x 160	1440	1872658	5205	150	130	645200	198	172	103	89	1758001	4883	2065	1428	1258	204
740	x	850	227	200	190	40	M27 x 160	1440	1924677	5205	146	127	654500	193	168	99	86	1809975	4892	2016	1436	1273	209
760	x	870	227	200	190	40	M27 x 160	1440	1976695	5205	142	124	663800	189	165	96	84	1861906	4900	1980	1446	1288	215
780	x	890	227	200	190	40	M27 x 160	1440	2028713	5205	139	122	673100	185	162	93	81	1913796	4907	1953	1457	1304	220
800	x	910	227	200	190	42	M27 x 160	1440	2184768	5462	142	125	777900	194	170	90	79	2041588	5104	2220	1554	1372	225

More sizes on request

### Explanations

<b>d</b> = Inner diameter	<b>P<sub>w</sub></b> = Surface pressure on shaft at given T <sub>A</sub>	<b>T<sub>res</sub> at M<sub>bmax</sub></b> = Remaining transmissible torque at indicated Mbmax and specified torque
<b>D</b> = Outer diameter	<b>P<sub>N</sub></b> = Surface pressure on hub at given T <sub>A</sub>	<b>F<sub>ax</sub> at M<sub>bmax</sub></b> = Transmissible axial force at max. bending moment
<b>L</b> = Overall length	<b>M<sub>bmax</sub></b> = Max. bending moment under the specified T <sub>A</sub>	<b>D<sub>N min</sub> at R<sub>p0,2</sub></b> = Min. hub outer diameter depending of the given hub yield point R <sub>p0,2</sub> and part of bending moment
<b>L<sub>1</sub></b> = Overall length (without screws)	<b>P<sub>wmax</sub> at M<sub>bmax</sub></b> = Max. surface pressure on shaft at max. bending moment	<b>G<sub>w</sub></b> = Weight
<b>L<sub>3</sub></b> = Width of ring	<b>P<sub>Nmax</sub> at M<sub>bmax</sub></b> = Max. surface pressure on hub at max. bending moment	
<b>n<sub>Sc</sub></b> = Quantity of screws	<b>P<sub>wmin</sub> at M<sub>bmax</sub></b> = Min. surface pressure on shaft at max. bending moment	
<b>D<sub>G</sub></b> = Thread	<b>P<sub>Nmin</sub> at M<sub>bmax</sub></b> = Min. surface pressure on hub at max. bending moment	
<b>T<sub>Ared</sub></b> = Reduced tightened torque of the screws under bending load		
<b>T</b> = Transmissible torque at given T <sub>A</sub>		
<b>F<sub>ax</sub></b> = Transmissible axial force		

### Ordering example

Locking Assembly	d	D
RfN 7015.0	240	305

#### Technical Information

- Surface finishes: Shaft and hub bores R<sub>a</sub> ≤ 3,2 μm
- Tolerances: Shaft: h8 · Hub: H8

**Remark:** The Values of the shaft- and hub pressures have been calculated with the screw tightening shown in the tables. Increase resp. reduction of the screw tightening torque results in different calculation values!

The specified pressures at M<sub>bmax</sub> are sometimes very low. An operation near these limit values may therefore lead to increased fretting corrosion! More options with reduced bending moments (M<sub>b</sub> 20% - M<sub>b</sub> 80%) are also available.

Further information on  
**RINGFEDER® RfN 7015.0**  
 for Bending Loads  
 on [www.ringfeder.com](http://www.ringfeder.com)

#### Disclaimer of liability

All technical details and notes are non-binding and cannot be used as a basis for legal claims. The user is obligated to determine whether the represented products meet his requirements. We reserve the right carry out modifications at any time in the interests of technical progress.