

Locking Assemblies

RINGFEDER® RfN 7061 stainless steel

Two piece, self-centering design



self-centering without axial displacement with low surface pressure

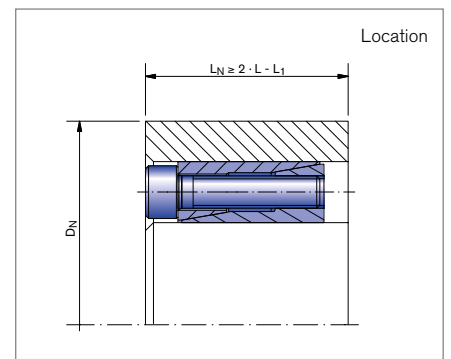
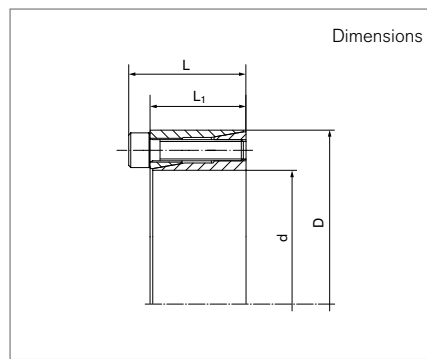

Locking Assembly dimensions					Transmissible torques or axial forces		Surface pressure		Locking screws			
d	x	D	L	L ₁	T	F _{ax}	Shaft PW	Hub PN	n _{Sc}	D _E	T _A	Gw
mm			mm		Nm	kN	N/mm ²				Nm	kg
6	x	16	13,5	11	3	0,9	49	19	3	M2,5	0,5	0,012
6,35	x	16	13,5	11	3	0,9	49	19	3	M2,5	0,5	0,012
7	x	17	13,5	11	3	0,9	42	17	3	M2,5	0,5	0,013
8	x	18	13,5	11	4	0,9	37	17	3	M2,5	0,5	0,015
9	x	20	15,5	13	6	1,2	37	17	4	M2,5	0,5	0,02
9,53	x	20	15,5	13	6	1,2	37	17	4	M2,5	0,5	0,019
10	x	20	15,5	13	6	1,2	33	17	4	M2,5	0,5	0,019
11	x	22	15,5	13	7	1,2	30	15	4	M2,5	0,5	0,024
12	x	22	15,5	13	7	1,2	26	15	4	M2,5	0,5	0,022
14	x	26	20	17	19	2,5	57	30	4	M3	1,3	0,039
15	x	28	20	17	22	2,5	55	27	4	M3	1,3	0,044
16	x	32	21	17	38	4	71	35	4	M4	2,9	0,066
17	x	35	25	21	41	4	66	33	4	M4	2,9	0,092
18	x	35	25	21	44	4	63	33	4	M4	2,9	0,087
19	x	35	25	21	46	4	60	33	4	M4	2,9	0,084
20	x	38	26	21	82	8	77	41	4	M5	5,7	0,1
22	x	40	26	21	88	7	71	38	4	M5	5,7	0,11
24	x	47	32	26	193	15	108	41	4	M6	14	0,2
25	x	47	32	26	201	15	104	41	4	M6	14	0,19
25,4	x	47	32	26	205	15	100	41	4	M6	14	0,19
28	x	50	32	26	341	23	143	55	6	M6	14	0,2
30	x	55	32	26	364	23	135	52	6	M6	14	0,27
32	x	55	32	26	387	23	127	52	6	M6	14	0,25
35	x	60	37	31	565	23	127	52	8	M6	14	0,36
38	x	65	37	31	620	31	120	49	8	M6	14	0,43
40	x	65	37	31	651	31	112	49	8	M6	14	0,4

To continue see next page

Locking Assemblies RINGFEDER® RfN 7061 stainless steel

Locking Assembly dimensions					Transmissible torques or axial forces		Surface pressure		Locking screws			
d	x	D	L	L ₁	T	F _{ax}	Shaft p _w	Hub p _N	n _{Sc}	D _G	T _A	G _w
mm			mm		Nm	kN	N/mm ²				Nm	kg
42	x	75	44	36	930	42	127	49	6	M8	34	0,75
45	x	75	44	36	1007	42	120	49	6	M8	34	0,7
48	x	80	44	36	1433	58	151	63	8	M8	34	0,8
50	x	80	44	36	1472	58	143	63	8	M8	34	0,76

More sizes on request

Explanation

d = Inner diameter	F_{ax} = Transmissible axial force	D_G = Thread
D = Outer diameter	p_w = Surface pressure on shaft at given T _A	T_A = Tightening torque of the clamping screws
L = Overall length	p_N = Surface pressure on hub at given T _A	G_w = Thread
L₁ = Overall length (without screws)	n_{Sc} = Quantity of screws	
T = Transmissible torque at given T _A		

Ordering example

Locking assembly	d	D	Further details
RfN 7061 stainless steel	25	47	SST (=stainless steel)

Technical Information

- Surface finishes: Shaft and hub bores R_a ≤ 3,2 μm
- Tolerances: Shaft: h8 · Hub: H8

Further information on
RINGFEDER® RfN 7061 stainless steel
 on www.ringfeder.com

Disclaimer of liability

All technical details and notes are non-binding and cannot be used as a basis for legal claims. The user is obligated to determine whether the represented products meet his requirements. We reserve the right carry out modifications at any time in the interests of technical progress.